

BlueWave[®] 200 Version 1.1

UV Light-Curing Spot Lamp System
with Patented Intensity Control Adjustment



BlueWave[®] 200 Version 1.1 (PN 38905 – North American / PN 38605 – International) shown with 4-pole lightguide

Operation Manual

TABLE OF CONTENTS

Unpacking and Inspection	Page 4-5
Safety	Page 5-7
General Information	Page 8
Specifications	Page 9
Installation and System Interconnect.....	Page 10
Settings & Adjustments.....	Page 11-14
Intensity Adjustment.....	Page 11
Intensity Validation	Page 11
Intensity Control	Page 11
Setting the Cycle Duration	Page 11-12
Lamp Dual-Hour Meter	Page 13
Bulb Replacement Procedure	Page 13-14
Operation	Page 15-17
Maintenance	Page 18
Troubleshooting	Page 19
Frequently Asked Questions.....	Page 19-20
Spare Parts List	Page 21
Definition of Terms.....	Page 22
Warranty	Page 23

The enclosed BlueWave® 200 UV Light-Curing Spot Lamp System was developed and manufactured by the DYMAX team, driven by a desire to best serve your needs. Before shipping, your *BlueWave 200* was thoroughly checked and tested for trouble-free performance.

The proper set up and operation of this Spot Lamp System will maximize safety and user-friendly performance, providing optimum yield of your technological process.

THEREFORE, WE ENCOURAGE YOU TO READ, UNDERSTAND, AND FOLLOW ALL SAFETY AND OPERATING INSTRUCTIONS AND RECOMMENDATIONS COMPILED IN THIS AND OTHER RELATED MANUALS prior to setting up and operating this new Spot Lamp System or its individual components.

Par conséquent, nous vous encouragez à lire, comprendre, et suivre toute sécurité et instructions d'opération et conseils rédigés dans cette et autres manuels établis un lien avant de mettre en place et de faire fonctionner ce nouveau système de lampe de tâche ou ces composants individuels.

If you encounter a problem, have any questions, or would like to help us with your suggestions or recommendations, please contact our Applications Engineering or Customer Service Departments. Trained DYMAX professionals are standing by to serve you.

Si vous rencontrez un problème, avez n'importe de questions, ou si vous voudrez de nous aider avec vos suggestions ou conseils, s'il vous plaît contactez notre département technique ou service client. DYMAX formé professionnels attendent à vous servir.

UNPACKING AND INSPECTION

Upon receipt of the unit, carefully remove the contents from the boxes and check for damage. **DYMAX is not responsible for damage from shipping – all claims for shipping damage should be made with the carrier.**

Check all boxes for contents and write down any serial numbers for further reference. You may wish to retain the original shipping cartons in case you need to repackage any item for return.

If you observe or experience any problem with your equipment, notify DYMAX Customer Service, your authorized distributor, or your DYMAX Representative immediately.

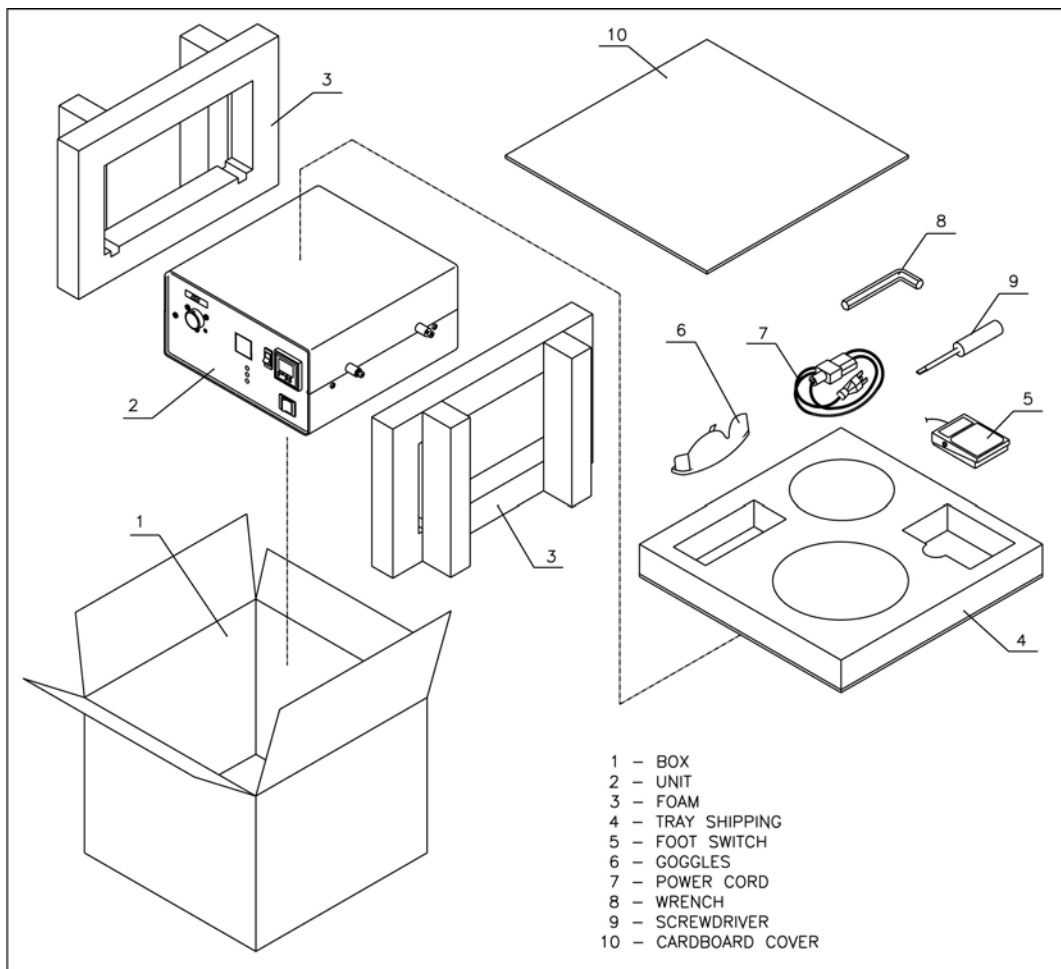

Figure 1. BlueWave 200 (PN38905 & PN38605) Unpacking Diagram

NOTE: Units are shipped with the Bulb/Reflector installed.

NOTE: Report any shortage to DYMAX Customer Service.

Before continuing with unpacking and installation, please read the following chapters of this manual for safety recommendations, installation, operating, and troubleshooting instructions.



CAUTION! Always wear protective goggles or face shield when working near the front of the unit, which emits UV light! The rear of the unit also emits stray UV light.



WARNING! Always observe safety requirements!



CAUTION! Risk of electrical shock if cover is removed!



CAUTION! Cover is warm to the touch when unit is in operation!



PRÉ-CAUTION! Toujours faire de l'usage des lunettes de protection ou protéger de visage marche près du devant d'élément!



AVERTISSEMENT! Remmarquez toujours besoin de sécurité!



PRÉ-CAUTION! Risque de décharge électrique quand le couvert est enlever!



PRÉ-CAUTION! Le couvert est chaud a le touche quand l'élément est en opération!



ACHTUNG! Tragen Sie immer eine Sicherheitsbrille oder einen Gesichtsschutz, wenn Sie nahe an der UV Lichtquelle arbeiten. Die Rückseite des Gerätes emittiert gestreutes UV Licht!



WARNHINWEIS! Bitte beachten Sie immer die Sicherheitshinweise!



ACHTUNG! Gefahr eines Stromschlages bei geöffnetem Gehäuse!



ACHTUNG! Gehäuse erwärmt sich während des Betriebs: Vorsicht bei Berührung!

SAFETY

Equipment is designed to be used properly set up, with components correctly connected, and operated in accordance with relevant instructions. The system's design was developed to maximize operator safety and minimize exposure to UV.

SAFETY RECOMMENDATIONS:

- Use the goggles provided or a face shield approved for UV protection to protect your eyes.
- Long-sleeved shirts or a lab coat are recommended to protect the arms and use of UV-opaque gloves will protect the hands.

NOTE: With the internal Filter installed, the BlueWave® 200 emits UVA and visible light. Never look directly at the light source while the unit is on.

SÉCURITÉ

L'équipement être conçu pour être utilisé correctement constituer, avec composants brancher correctement, et marché en conformément avec instructions important. Le plan étai développer pour rendre au maxime opérateur sécurité et minimiser exposition à ultraviolette.

RECOMMANDER DE SÉCURITÉ:

- Emploi lunettes ou un protéger de visage pour protection de ultraviolet pour protéger vous yeux.
- Chemises à manche long ou manteau de labo sont recommander pour protéger les bras, et utilisation de ultraviolette gants opaque vais protéger les mains.

REMARQUER: avec le filtre intérieur installé, l'Onde Bleu émettre UVA et lumière visible. Ne jamais regardez directement à la source de lumière pendant que l'élément est en opération.

SICHERHEITSHINWEISE

Dieses Gerät wurde so entwickelt, dass es nur vollständig, alle Komponenten korrekt miteinander verbunden, in Übereinstimmung mit relevanten Instruktionen betrieben wird. Bei der Entwicklung wurde weiterhin großen Wert auf die Benutzersicherheit und minimale UV Belastung gelegt.

SICHERHEITSHINWEISE:

- Tragen Sie immer die mitgelieferten Sicherheitsbrille oder speziellen Gesichtsschutz, der Ihre Augen vor UV Licht schützt.
- Wir empfehlen Langarm - Hemden oder einen Laborkittel zu tragen, um die Arme zu schützen. Für die Hände empfehlen wir UV- geblockte Handschuhe.

BITTE BEACHTEN SIE: Durch den installierten inneren Filter strahlt die *BlueWave 200* UVA und sichtbares Licht aus. Schauen Sie deshalb niemals direkt in die Lichtquelle, wenn das Gerät angeschaltet ist.

DYMAX UV LIGHT-CURING SYSTEM SAFETY CONSIDERATIONS

DYMAX UV light-curing technology has been used successfully for over 30 years. The fast cure, one-component nature of our UV light-curing technology has made it the process of choice for many manufacturers requiring a "cure on demand" assembly process. There are four common questions/concerns related to UV light-curing systems: UV exposure, high-temperature surfaces, ozone, and bright, visible light.

UV EXPOSURE

Standard DYMAX UV light-curing systems and bulbs have been designed to primarily emit UVA light (as shown in Chart 1). UVA light is generally considered the safest of the three UV ranges: UVA, UVB, and UVC. Although OSHA does not currently regulate ultraviolet light exposure in the workplace, the American Conference of Governmental Industrial Hygienists (ACGIH) does recommend Threshold Limit Values (TLV's) for ultraviolet light. The strictest interpretation of the TLV (over the UVA range) for workers' eyes and skin is 1 mW/cm^2 (intensity), continuous exposure. Unless workers are placing bare hands into the curing area, it is unusual to exceed these limits. To put 1 mW/cm^2 limit into perspective, cloudless summer days in Connecticut regularly exceed 3 mW/cm^2 of UVA light and also include the more dangerous UVB light (primarily responsible for sun tans, sun burns, and skin cancer) as well.

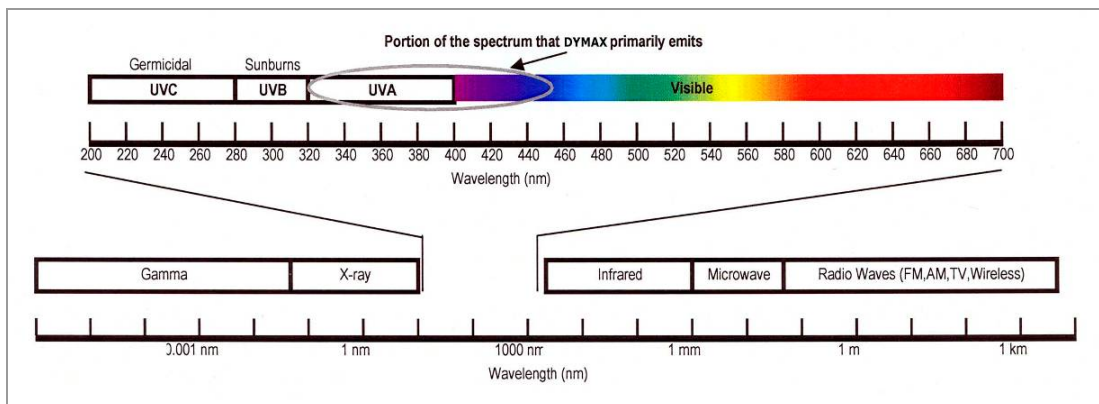

Chart 1. Light Spectrum

The human eye can not detect “pure” UV light, only visible light. A radiometer should be used to measure stray UV light to confirm the safety of a UV light-curing process. A workstation that exposes an operator to more than 1 mW/cm² of UVA continuously should be redesigned.

UV light-curing of adhesives can be a regulatory compliant, “worker-friendly” manufacturing process when the proper safety equipment and operator training is utilized. There are two ways to protect operators from UV exposure: shield the operator and/or shield the source.

SHIELD THE OPERATOR

- **UV-Blocking Eye Protection** – UV-blocking eye protection is recommended when operating UV light-curing systems. Both clear and tinted UV-blocking eye protection is available from DYMAX.
- **UV-Blocking Skin Protection** – Where the potential exists for UV exposure upon skin, opaque, UV-blocking clothing, gloves, and full-face shields are recommended.

SHIELD THE SOURCE OF UV

Any substrate that blocks UV light can be used as a shield to protect workers from stray UV light. The following materials can be used to create simple shielding structures or blind corners:

- **Sheet Metal** – Aluminum, steel, stainless steel, etc. Sheet metal should be coated black or black anodized to minimize reflection of UV and visible light toward operators.
- **Rigid Plastic Film** – Transparent, UV-blocking plastics (typically polycarbonate or acrylic) are commonly used to create shielding where transparency is also desired. These rigid plastic films are available either water-clear or tinted.
- **Flexible Film** – UV-blocking, flexible urethane films can be used to quickly create workstation shielding. This UV-blocking, flexible urethane film is available from DYMAX.

HIGH-TEMPERATURE SURFACES

Surfaces exposed to high-intensity curing lights will rise in temperature. The intensity, distance, exposure time, cooling fans, and the type/color of the surface can all affect the actual surface temperature. In some cases, exposed surfaces can reach temperatures capable of producing a burn or causing damage to a substrate. In these cases, care must be taken to ensure a more moderate surface temperature or appropriate protection/ training for operators.

OZONE

Standard DYMAX bulbs (UVA type) generate an insignificant amount of UVC and therefore essentially no ozone. Some UV light-curing systems, like those used to cure UV inks, emit primarily “shortwave” (UVB and UVC) energy. Upon exposure to UVC light (specifically <240 nm), oxygen molecules (O₂) split into oxygen atoms (O) and recombine with O₂ to create ozone O₃. The current, long-term ozone concentration limit recommended by ACGIH, NIOSH, and OSHA is 0.1 ppm (0.2mg/m³).

BRIGHT, VISIBLE LIGHT

The bright, visible light emitted by some UV light-curing systems can be objectionable to some workers and can cause eyestrain. Tinted eye protection and/or opaque/tinted shielding can be utilized to address this concern.

SUMMARY

UV light sources can be more “worker friendly” than many commonly accepted industrial processes, provided the potential concerns are addressed. Contact your DYMAX representative for information regarding the proper use of DYMAX UV light-curing systems.

GENERAL INFORMATION

The BlueWave® 200 is a high-intensity, UV light-curing spot lamp used for the curing of adhesives, coatings, and potting materials. It emits UV light from a Lightguide, which is sold separately. The Lightguide can be hand-held for complete mobility, clamped into position for repetitive operations, or in automated equipment.

The unit consists of an anodized aluminum housing, containing an electronic Power Supply, Circuit Protection, Bulb/Reflector Assembly, Internal Light Filter for extended Lightguide life, thermostatically controlled Cooling Fans, Lightguide Mount, Bulb Status Indicator Light, combination resetable and non-resetable Hour-Meter, and Shutter system. A Thermal Shutdown Sensor is provided for internal temperature control of the unit. Fan Filters should be changed or cleaned frequently to prevent blockage and reduced ventilation airflow. Electric Shutters are supplied with timed and manual shutter operating modes. The Lightguide is separate and plugs into the Lightguide Mount.

A patented Intensity Control Feature allows operators to manually adjust output intensity during process validation and production. Users can now manually adjust intensity to compensate for bulb degradation.

WARNING: Engage the Lightguide in the Bezel before the light is turned on, and remove the Lightguide from the Bezel ONLY AFTER the light is turned off to avoid the possibility of exposure to the light. Lightly tighten the setscrew for safety.

AVERTISSEMENT: Engager le guide de lumière dans le biseau avant la lumière est allumer, et enlève le guide de lumière de le biseau SEULEMENT après la lumière est fermer pour éviter la possibilité d'exposition à la lumière. Reserrer doucement la vis pour sécurité,

The Blue Indicator Light above the Bezel lights when the Bulb is operating. The Power Supply operates on line voltages of either 115 or 230 Vac, 50/60 Hz. If the Bulb extinguishes due to a momentary power failure, the unit must be turned off, allowed to cool, and then turned on again to re-ignite the Bulb.

A Cooling Fan is provided to keep the Bulb Housing and internal components of the Power Supply at the optimum operating temperature. The Cooling Fan must not be covered or otherwise blocked. The UV source is a 200-Watt short-arc mercury-vapor Bulb mounted in a Reflector and pre-focused to provide optimum light output. The unit is rated for continuous operation.

SPECIFICATIONS

Part Number	PN 38905 – North American Version (with 115V standard plug) PN 38605 – International Version (with no plug)
Intensities	Total (280-450) 40+ W/cm ² Visible (400-450nm) 17+ W/cm ² UVA ¹ (320-395nm) 17+ W/cm ² UVB (280-320nm) 7 W/cm ²
Power Requirements	90-265, 47-63 Hz
Power Supply	Solid State, 200 Watt
Bulb	200-Watt mercury bulb included; replacement in less than a minute
Reflector	Elliptical; glass with dichroic coating to reflect UV and minimize IR
Shutter Timer	Digital LCD timer up to 99.99 seconds; manual or timed shutter
Shutter Activation	Foot switch or PLC
I/O Port	9-pin D – sub-miniature connector
Signals (PLC Integration)	Inputs Shutter activate, Shutter de-activate Outputs Lamp on, lamp off, replace lamp Shutter opened, shutter closed, shutter fault
Cooling	Filtered, dual-fan arrangement; thermally controlled to maintain proper lamp temperature
Hour Meter	Digital LCD; Total unit operating hours (non re-settable) Total Bulb hours (re-settable)
Housing Dimensions	12.0" x 12.25" X 6.5" (30.5cm x 31.1cm x 16.5cm)
Weight	14 lbs. (6.0 kg)
System Warranty	1 year from purchase
Bulb Warranty	2,000 hours (no intensity warranty, only Bulb ignition)
Replacement Bulb	PN 38465

¹ Measured with an EIT Spotcure Radiometer or an ACCU-CAL™ 50 Radiometer using a Lightguide Simulator and standard internal "Cool Blue" Filter.

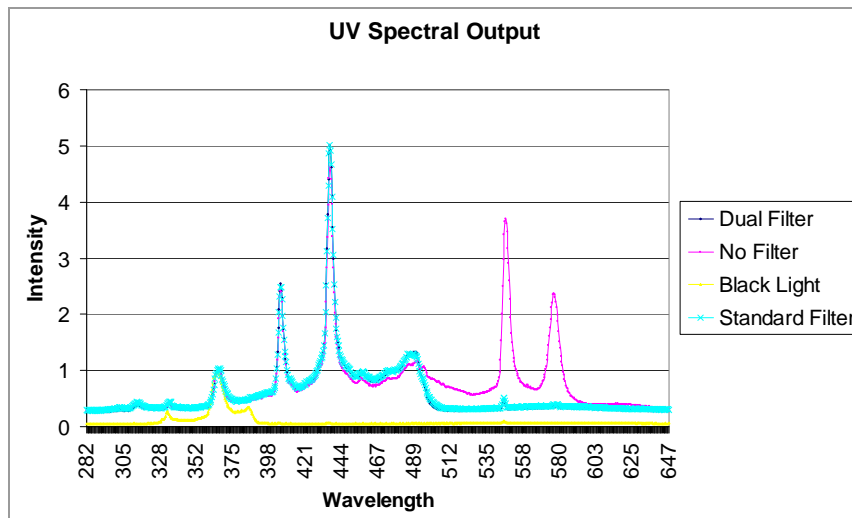

Figure 2. 200W Bulb Spectral Chart

INSTALLATION AND SYSTEM INTERCONNECT

1. Connect the Power Cord to the Power Receptacle on the rear of the unit and plug the Power Cord into a grounded wall outlet.
2. Connect the Footswitch to the Footswitch Connection (Figure 3) in the rear of the unit. A ground stud is provided on the back of the unit if additional grounding is desired.
3. Remove the protective cover from the BlueWave® 200's Lightguide Mount (Figure 4).

NOTE: Always have a Lightguide or the protective cap engaged in the Lightguide Mount. UV light can escape when the Shutter is activated.

4. Remove the protective end caps from the Lightguide. Visually inspect the two ends of the Lightguide to verify that no foreign material is present. The ends of a DYMAX liquid-filled Lightguide can be cleaned with isopropyl alcohol as required to remove foreign material and deposition from outgassing.
5. Insert the large end of the Lightguide into the Lightguide Mount until it snaps into place (Figure 5).
6. If desired, the Lightguide may be fastened into place by lightly tightening the securing setscrew installed in the Lightguide Mount (Figure 6). A hex wrench is provided with the *BlueWave 200* for this purpose. The setscrew should be tightened gently to prevent damaging the Lightguide.

NOTE: Multi-leg Lightguides should be balanced by rotating the Lightguide to obtain the desired UV intensity of each leg before tightening the setscrew.

7. Turn the *BlueWave 200's* Power Switch on.
8. Allow the Bulb to warm up 4-5 minutes to obtain the maximum light output.

CAUTION: This is an arc, not a filament Bulb. Once ignited, it must be left on for a minimum of 10 minutes to fully vaporize elements in the Bulb. If not, the Bulb may be difficult to re-ignite. Each re-ignition increases the rate of Bulb degradation.

NOTE: The Bulb must cool before it can be re-ignited. Turn the unit off and allow 5 to 10 minutes for it to cool down. If the Bulb fails to ignite, refer to the Troubleshooting Section of this manual. Bulb life is reduced each time the unit is switched on and off. Avoid repeated cycles that shorten Bulb life by leaving unit on through breaks.

9. Operate the Shutter by pressing the Footswitch. With the Shutter Selector Switch in the manual position, the Shutter operates directly from the Footswitch. In the timed position, the Shutter opening is determined by the setting on the electronic Timer. Simply push the Timer Setting Buttons to enter the desired number of seconds the Shutter is to remain open.
10. With the Shutter open, adjust the Intensity Adjustment Screw as required to achieve the desired output intensity (Figure 6).

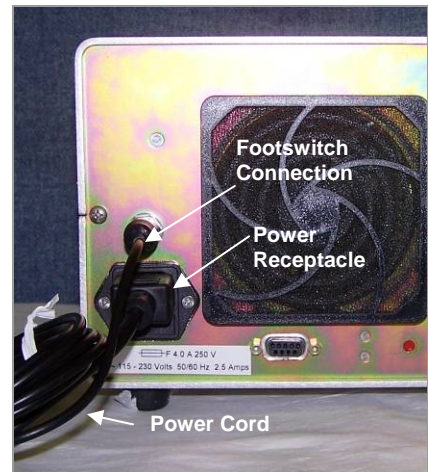

Figure 3. Cable Connection, *BlueWave 200* Rear Panel



Figure 4. Lightguide Mount Protective Cover Installed (left); Protective Cover Removed (right)

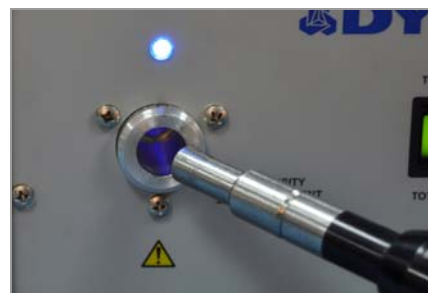

Figure 5. Insert Lightguide into Lightguide Mount



Figure 6. Adjust the Intensity Adjustment Screw

SETTINGS AND ADJUSTMENTS

PATENTED INTENSITY ADJUSTMENT

The Bulbs used to power all high-intensity UV light-curing Spot Lamps degrade with use. Intensity, therefore, decreases as the Bulb ages. Using the BlueWave® 200's patented Intensity Control Feature, users can eliminate this variation by manually increasing output intensity to offset this degradation.

The intensity can be adjusted with a tool (Figure 7) or a removable knob (Figure 8). This feature is useful for both validation and control.



Figure 7. Intensity Adjustment with Tool



Figure 8. Intensity Adjustment with Knob

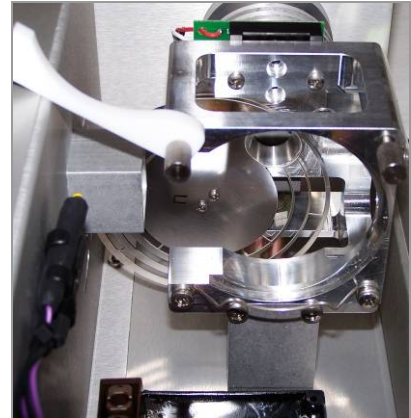

Figure 9. Intensity Adjustment (Interior View)

INTENSITY VALIDATION

Prior to production, DYMAX advises customers to conduct testing to determine the time and intensity required to fully cure their resin in their specific application. Typically, users validate by one of the following methods:

- **Set Exposure Time, Determine Intensity** - Users can specify a cure time and through empirical testing, determine the intensity required to achieve full cure. As with any manufacturing process, it is advisable to incorporate a safety factor.
- **Set Intensity, Determine Exposure Time** - Users can specify intensity and through empirical testing, determine the exposure time required to achieve full cure. As with any manufacturing process, it is advisable to incorporate a safety factor.

INTENSITY CONTROL

Process validation confirms a minimum acceptable intensity. Users can then choose to operate at full intensity (using the excess intensity as an additional safety factor) or maintain a constant intensity through periodic manual adjustments. *BlueWave 200* Bulbs will typically vary less than 1% over eight hours of normal use and so daily or weekly adjustments are adequate to maintain a tightly controlled process. A Change Bulb Indicator Light is provided to alert the operator to check Bulb operation or to change the Bulb if required.

SETTING THE CYCLE DURATION

The Shutter Timer located on the front panel of the BlueWave 200 is factory set to the most common operating mode and recommended operation of the Shutter Timer with the *BlueWave 200*. Some modes available on this Shutter Timer may not operate correctly with the *BlueWave 200* unit and have been disabled.

The front panel of the Shutter Timer contains a LCD Display and Keypad. The LCD Display has a Power Indicator, Signal Input Indicator, Reset Indicator, Gate Input Indicator, Key Protect Indicator, Output Indicator, present value, set value, and Timing Operation Indicator.

A brief description of each display and location:

- **PW [Power Indicator]** – Upper left corner of Timer Display. Displayed when external power for operation is present.
- **SIG [Signal Input Indicator]** – Upper left corner of Timer Display, located to right of Power Indicator. Displayed when activate signal is present.
- **OUT [Output Indicator]** - Displayed when relay is switched on; is not displayed when relay is switched to off.
- **Present Value** – Four digits segmented display in center of Timer. Shows current status of time.
- **Timing Operation Indicator** – Displays **RUN** in upper right corner to the left of Output Indicator. Displayed when Timer is active.
- **Set Value** – Four-digit segmented display in lower right corner of the Shutter Timer. Shows set length of time.
- **K/P [Key Protect]** –Will always be lit as the function of the Shutter Timer is programmed at the factory and locked before shipment.

In addition to the indicators, the Shutter Timer contains six buttons with their functions described as follows:

- **MODE** – Disabled at the factory and locked before shipment.
- **RST [Reset Indicator]** – Active when the Shutter Timer is reset by pressing the “RST” button on the lower left face of Shutter Timer.
- **Digit Increment 1-4:** Pressing these buttons up or down will increment or decrement that digit by one. The timer digits are formatted MM:SS for a maximum Shutter time of 99 minutes and 0.99 seconds. Consult DYMAX for information on changing the format of this Timer.



Figure 10. Shutter Timer

To set the Shutter open duration, press the appropriate up/down button until the corresponding digit increments in the set value. By pressing the key labeled (1), it will increment the left most digit on the set value. By pressing the key labeled (2), it will increment the second digit of the set value and similar for digits 3 and 4. The small grey buttons are “rocker” style so pressing the top half increments the digit up while pressing the bottom half will increment down. The Timer will increment from 9 back to 0. If the Timer is not operating, the Timer should

periodically update the present value with the set value. If the Timer does not, press the Reset Button. Reset value will become the present value. The Timer comes programmed for a range of 00.01 seconds to 99.99 seconds. Consult factory for other time ranges and functions.

To operate the Timer, select the Timer Operation Mode on the front panel (large Rocker Switch left of the Timer). Program the time into the Timer as described above and depress the Footswitch. Factory settings will open the Shutter and the present value will begin to count backward. When the Timer reaches 00.00, it will reset the value to the set value and close the Shutter. The Timer cannot be stopped once started. If power is removed from unit, the Timer will reset to set value.

LAMP DUAL-HOUR METER

The Lamp Dual-Hour Meter (Figure 11) provides elapsed time of unit operation (top display), as well as Bulb usage (bottom display). The top display (Elapsed-Time Meter) continues to count hours of operation on the unit and cannot be reset. The lower display reflects the number of hours on the Bulb. Bulb hours should only be reset when a new Bulb is installed.

When the Total Bulb Hours Line of the Lamp Dual-Hour Meter reaches 2,000 hours, the display will alternate between "CHANGE BULB" and "2000.0". This indicates that the Bulb has reached the end of its useful life and needs replacement. Instructions for Bulb replacement are found in the Bulb replacement section of this manual as well as being located on the sticker under the unit cover next to where the Bulb is located.

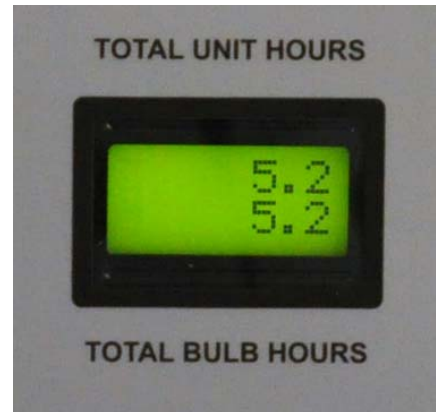

Figure 11. Lamp Dual-Hour Meter

WARNING: Operating a BlueWave[®] 200 Lamp beyond 2,000 hours will result in a non-passive failure of the Bulb! Do not reset the Lamp Dual-Hour Meter without replacing the Bulb.

BULB REPLACEMENT PROCEDURE

Bulb replacement is easily accomplished by following the steps below. Refer to the labeled diagrams under the light source cover.

1. Ensure that the Power Cord is unplugged from the rear of the unit.
2. Remove the top cover from the *BlueWave 200* by loosening the four cover fasteners.
3. Unplug the Bulb and Lift the Bulb Mounting Bracket (Figure 13) from it. Remove the Bulb from the Bulb Mount (Figure 14).



Figure 12. Bulb Installed in Bulb Mount

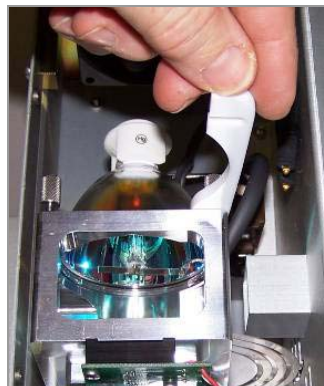

Figure 13. Lift Bulb Mounting Bracket

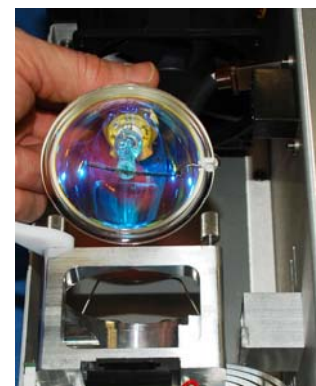

Figure 14. Remove Bulb from

4. Unpack the new Bulb. Take care not to bend the flat Electrode in the center of the Bulb.



Figure 15. Bulb Package (Closed)



Figure 16. Bulb Package (Open)



Figure 17. Remove Bulb from Box



Figure 18. Bulb

5. Install the new Bulb into the unit (Figure 19), plug the Bulb in (Figure 20), and tighten the two Mounting Bracket Thumbscrews (Figure 21).
6. Make sure that the center Electrode is positioned as shown in Figure 22.



Figure 19. Install Bulb



Figure 20. Plug in Bulb



Figure 21. Tighten Mounting Bracket Thumbscrews

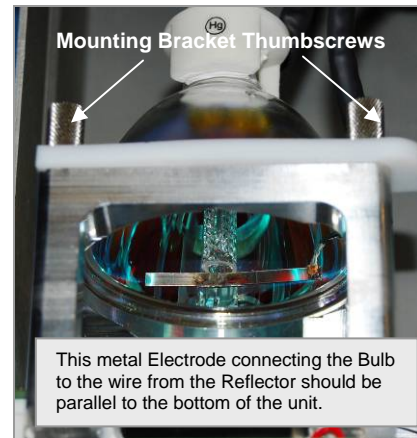

Figure 22. Bulb Electrode

7. Press Hour Meter Reset Switch (Figure 23).
8. Re-install the BlueWave® 200's cover.



Figure 23. Hour Meter Reset Button

9. This completes Bulb installation. The Bulb will now ignite. If the Bulb does not light, repeat instruction 5. The unit is now reset to operate for 2,000 hours.

10. Allow the Bulb to warm up for five minutes and then the unit is ready for use.

OPERATION

The BlueWave® 200 will arrive almost fully assembled. Please refer to the Installation and Interconnection Section for instructions on installation of the Lightguide, Power Cord, and Footswitch. The system should be positioned in a dry location that does not obstruct airflow from the rear of the unit.

IMPORTANT: To ensure proper operation of the Shutter, be sure to completely insert the Lightguide into the Lightguide Mount prior to tightening the setscrew. Be sure to lightly tighten the setscrew to ensure the Lightguide remains in place during use.

To energize the system turn the Power Switch from the “O” position to the “I” position; Fan, Hour Meter, Timer, and 200 Watt Lamp should begin to function. This can be confirmed by viewing the illuminated blue lens above the Lightguide Mount (Figure 25). Before operating unit, allow the 200 Watt Lamp to warm-up for approximately 5 minutes.

CAUTION: Always wear protective goggles or face shield when working near UV light. Never look directly at the light exiting the Lightguide.

PRE-CAUTION: Toujours porte lunettes de protection ou protéger de visage en travaillant près lumière ultraviolette. J’amais regarde directement à lumière sortie de le guide de lumière.

Position the Lightguide end no closer than ¼" from material being cured. Locating the Lightguide end too close can cause the Lightguide end to become cloudy from vapors coming off of curing material. This cloudiness can reduce UV output by as much as 50%.

Bulb life is reduced each time it is started. To avoid premature Bulb deterioration, leave the unit on through breaks, short shutdowns, and lunch hours. These UV light sources are designed for continuous operation. If the power is momentarily lost, shut the unit “off” and let it cool down for 5 to 10 minutes then switch back “ON” and wait for warm-up.

As the Bulb degrades, some adjustment may be needed to the Lamp intensity. To use the patented Lamp Intensity Adjustment, the Intensity Adjustment Knob must be installed. This knob installs into the Intensity Adjustment Screw.

9-PIN CONNECTOR I/O SIGNALS

The *BlueWave 200* is equipped with a 9-Pin D-Subminiature Connector (Figure 26) that provides interface between the *BlueWave 200* and PLC and similar factory-control equipment. The following discussion will describe inputs and outputs, their properties, and how to use them.

Input signals:

Pin 1 – Shutter Activate

This signal line may be used to remotely open the *BlueWave 200* Shutter. When it is being used, the local Shutter Enable Jack on the rear of the *BlueWave* is still capable of opening the Shutter. Similar to the local Shutter Enable, if the Timer/Manual Switch is in timer mode, the Shutter will stay open for the time set on the Timer. In the



Figure 24. BlueWave 200 Front Plate



Figure 25. Illuminated Blue Lens



Figure 26. 9-Pin I/O Signals

manual mode, the Shutter will stay open for the duration of the remote Shutter Activate Signal. The Shutter is opened when Pin 1 of the DSUB9 Connector is connected to Pin 2. When the connection between DSUB9 Connector Pins 1 & 2 is broken, the Shutter is closed.

Pin 7 – Shutter De-Activate

This signal line may be used to remotely prevent the Shutter of the BlueWave[®] from being open under any circumstances. If the operator wishes to use the Shutter deactivate feature they must first remove both Outer and Inner Cover Assemblies and remove Jumper JP-2 from the Communications Board.

200 Watt units are shipped from the factory with Jumper JP-2 installed on the Communications Board. This board is located on the rear of the OMRON Timer and can be accessed only by removing the Outer and Inner Cover Assemblies.

Once JP-2 is removed, this will allow the operator to remotely enable or disable the Shutter deployment from any input.

If using a PLC to control this signal, an isolated relay contact (normally open) will provide the proper sense in the event a disable of Shutter is required. Closing the contact, connecting Pin 7 to Pin 2 of the DSUB9 Connector will provide normal Shutter operation. Opening the connection between Pins 7 and 2 of the DSUB9 Connector will disable Shutter operation and leave the Shutter closed. Under this condition, the Shutter may not be operated locally or remotely.

In summary, both input signals are said to be enabled when there is electrical contact between their pin and Pin 2 of the 9-Pin D-Subminiature Connector. Closure can be supplied either by dry contacts or by Opto-Coupler output as shown in Figure 27.

Output Signals:

The output signals are all opto-isolated signals. Each signal has an NPN Output Transistor. The emitters of all Output Transistors are tied together and connected to the PLC common on DSUB9 Pin 4. Each individual Output Signal Line is connected to the collector of each Transistor. When the Transistor is turned on, this provides a ground to the PLC system that can be used to enable a relay coil or an enable signal to an Opto-Coupler. The Conducting Transistor can also function as a set of contacts that can initiate actions within the PLC. When the Transistor is on, the signal is said to be enabled or asserted. When the Transistor is off, the signal is said to be disabled or unasserted. The Transistors have a max current rating of 30 mA, and a max power rating of 150mW. Only positive voltages with respect to the PLC common should be used to a maximum of 24 V. D. C. Series Limiting Resistors should be used to insure that the max conditions are not exceeded.

Pin 3 - Shutter Fault

Pin 6 - Shutter Open

Shutter fault and Shutter open are gated by two Photocells monitoring the position of the Shutter. When the Shutter is closed, both Photocells will be conducting due to their exposure to Lamp intensity. When the Shutter begins to deploy to an open position, first Shutter fault, then Shutter open will be blocked from Lamp intensity by the Shutter Assembly itself. Should the Shutter get stuck, one of these signals will indicate the wrong sense, and will flag the problem.

When the Shutter is off, Pins 3 and 6 will be shorted to Pin 4. When the Shutter opens, both Pins will be open with respect to Pin 4. Since a shorted condition would be used to indicate a failure, these signals should only be polled 45 milliseconds after the Shutter closes. By this time they will be open with respect to Pin 4 in normal operation. Should either of these lines remain shorted to Pin 4 after the 45 millisecond delay, the operator should conclude that a Shutter fault condition exists.

Pin 8 – Lamp Lit

Pin 8 will be shorted to Pin 4 when the Bulb is lit. Pin 8 will be open with respect to Pin 4, during startup prior to the Bulb lighting, or if the Bulb has failed.

Pin 9 – Lamp Replace

When the Elapsed Time Meter reaches 2000 hours, it disables the Lamp from lighting. At this point in time, Pin 9 becomes shorted to Pin 4. Pin 8 will no longer be shorted to Pin 4 indicating that the Lamp is no longer lit. Otherwise, Pin 9 will be open with respect to Pin 4.

Pin 5 of the DSUB9 Connector is not used at this time.

Figure 10 shows the suggested relationship for both inputs and outputs between the BlueWave[®] 200 and a PLC system. The component values shown are appropriate for a 24 VDC PLC Power Supply to limit current flow to safe levels for the opto-coupler devices within the *BlueWave 200*.

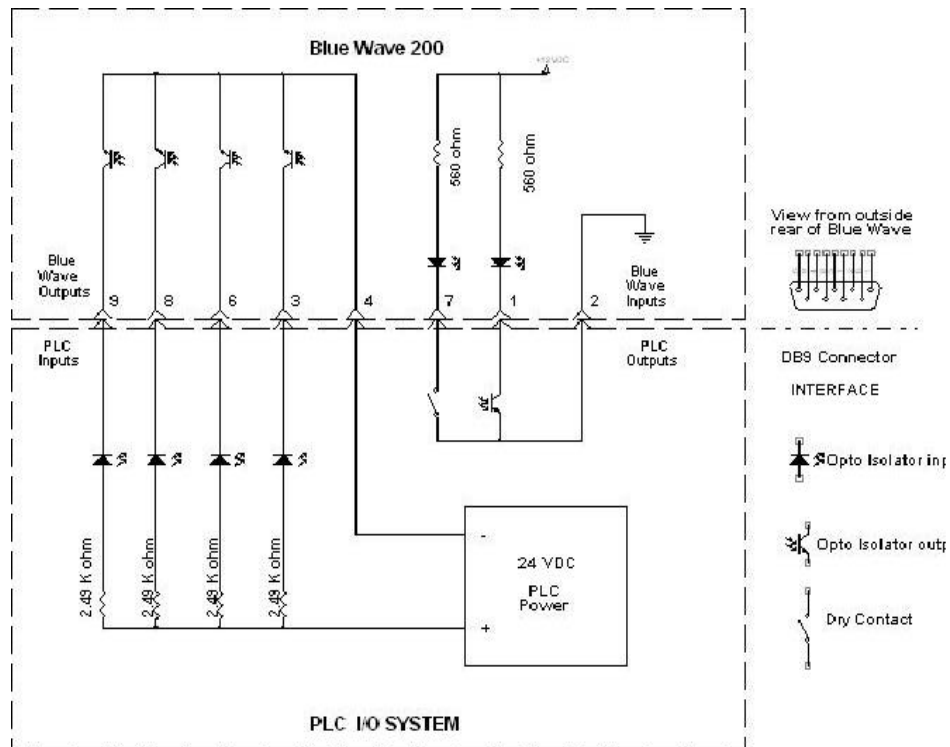

Figure 27. 9-Pin I/O Signals

MAINTENANCE

The BlueWave® 200 was designed to operate with a minimal amount of maintenance. Follow the schedule below to assure top performance from the unit.

LIGHTGUIDE

Clean the ends of the Lightguide monthly or as required. The ends of the Lightguide should be kept clean to transmit as much light as possible. Cured adhesive can be removed with a razor blade. Avoid sharp bends with the Lightguide since this reduces light output and damages guide.

FAN FILTERS

The external Fan Filters should be inspected and cleaned periodically to prevent dust buildup from affecting airflow through the unit. Spare Fan Filters are provided with each unit and with replacement Bulbs. The Fan Filters are washable and may be reused. Remove the Fan Filter by removing the snap-on cover from the rear of each grill.



Figure 28. Exhaust Fans with Fan Filters Removed

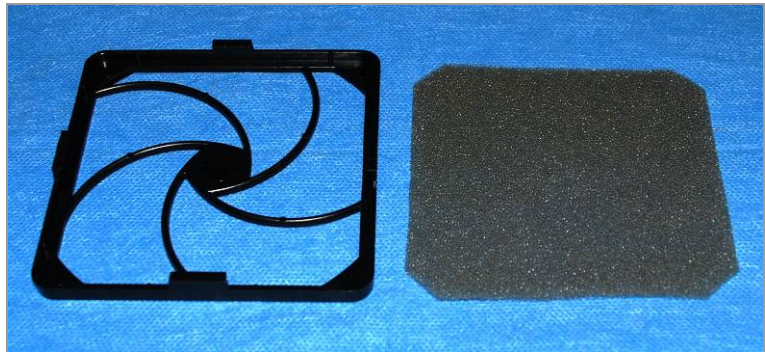

Figure 29. Disassembled Fan Filter

FUSE REPLACEMENT

The unit has two Fuses that are installed in the Power Receptacle. To remove the Fuses, unplug the unit and remove the Fuse Holder with a small screwdriver. Remove the Fuses from the Fuse Holder and install new Fuses. Replace the Fuse Holder into the Power Receptacle. The correct Fuses are DYMAX PN 37869, 4.0 Amp fast-acting type.



Figure 30. Power Receptacle



Figure 31. Fuse Holder

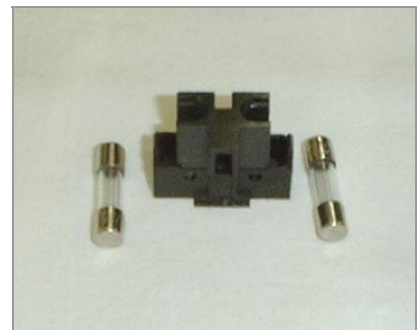

Figure 32. Fuses Removed from Holder

TROUBLESHOOTING

WARNING: Only qualified maintenance personnel should attempt the following procedures:

AVERTISSEMENT: Seulement personnel d'entretien diplômé devrais essayer les procedures suivant.

Problem	Possible Cause	Testing	Corrective Action
Bulb Will Not Ignite	Improper connections	Visually inspect all input/output connections (i.e. Power Cord, Bulb).	Secure all connections.
	Bulb beyond useful life of 2,000 hours	Replace with a new Bulb/ Reflector Assembly. Reset the Bulb Hour Meter and re-test unit.	Replace the Bulb/Reflector Assembly if required (typical life = 2,000 hours).
	Main line Fuse blown (nothing in unit operates)	Remove the Fuse from the Power Receptacle and check it with an Ohmmeter.	Replace the Fuse if defective.
Low Output Intensity or Fails To Cure Adhesive In Allotted Time	Bulb beyond useful life	Use a Radiometer (DYMAX ACCU-CAL™ 50 or equivalent) to measure output intensity.	Replace the Bulb/reflector assembly if beyond useful life (typical = 2,000 hours).
	Transmission loss in Lightguide too great	Compare Lightguide output against new Lightguide (or use the DYMAX Lightguide Simulator) to determine transmission loss.	Replace the Lightguide.
	Contaminants on Lightguide	Visually examine ends of Lightguide for contaminants.	Clean with isopropyl alcohol (or equivalent). Heavy deposits on liquid Lightguides may be removed with a razor blade. Replace Lightguide if it can not be cleaned.
	Bulb/Reflector Assembly not installed properly	Visually check to make sure the Bulb/Reflector Assembly is seated flush in the Bulb Mount Assembly (any error in installation could cause a low output).	Properly install Bulb/Reflector Assembly.

FREQUENTLY ASKED QUESTIONS

Q: The blue lens on the front panel does not light.

A: This signifies the Bulb has not ignited. Check that the Power Cord and Bulb connections are secure.

Q: The Bulb will not ignite; it only “flickers”.

A: Replace the Bulb. Excessive power cycling will shorten the life expectancy of the Bulb. This is an arc, not a filament Bulb. Once ignited, it must be left on for a minimum of 10 minutes to fully vaporize elements in the Bulb. If not, the Bulb may be difficult to re-ignite. Each re-ignition increases the rate of Bulb degradation.

Q: I installed a new Bulb, and it still will not ignite.

- A: The BlueWave[®] 200 has a safety shutdown feature at 2,000 hours. If the equipment has reached the safety shutdown point, the lower display on the Hour Meter will alternate between "Change Bulb" and "2000.0", and the Bulb will not light. When this happens, the *BlueWave 200* will no longer supply an ignition voltage until a new Bulb is installed and the Reset Switch is pressed on the back of the unit. The power must be on for this reset to be performed. The Reset Switch should always be pressed whenever a new Bulb is installed and a Bulb should never be operated after it reaches the 2,000 hour life expectancy.
- B: Check and make sure the Bulb Connector is fully seated into the Igniter.

Q: Why do I have low intensity, even with a new Bulb?

- A: Standard *BlueWave 200* units have a Filter Lens installed, which filters the light before it reaches the Lightguide. The light intensity will be decreased as the light that passes through the filter is restricted by dust and debris.
- B: The intensity is being checked too early. The 200 Watt Bulb will not reach full intensity for five minutes.
- C: The Lightguide may not be fully seated into the Lightguide Mount.
- D: The end of the Lightguide may have a build-up of adhesive. Carefully remove with isopropyl alcohol or use a razor blade for heavier deposits.
- E: The condition of the Lightguide will also affect the intensity. All Lightguides degrade with time, but intensity will also drop if the Lightguide is bent or compressed. The intensity reading from the Lightguide should be compared to the intensity reading from a Lightguide Simulator to determine the efficiency.
- F: Incorrect installation of the Bulb. Bulb orientation is vital during the installation of the Bulb. Refer to the Bulb installation instructions supplied with all new 200 Watt Bulbs for the proper installation procedure.

Q: My Footswitch is not operating.

- A: Check the connection of the Footswitch into the unit.

Q: What causes my Shutter to hesitate to open when I activate my Footswitch?

- A: Maintaining clean equipment and a clean working environment will help prevent the build up of dust and other debris from collecting on the mechanical parts of the *BlueWave 200*. Debris that settles in the piston well (adjustment screw) can hinder the movement of the Shutter solenoid piston.
- B: Shutter alignment to Reflector Mount incorrect.
- C: The Shutter is a mechanical part which may wear after extended use.
- D: Incorrect alignment of the Shutter to the Bulb Mount Assembly.

Q: Why does my Shutter sometimes hesitate to close?

- A: This problem may also relate to the cleanliness of the working environment. Dust and debris can collect and cause the Shutter to work improperly.
- B: Shutter alignment to Reflector Mount incorrect.
- C: The Shutter is a mechanical part which may wear after extended use.
- D: Incorrect alignment of the Shutter to the Bulb Mount Assembly.

Q: Why does my *BlueWave 200* seem to run very hot?

- A: Replace the Fan Filter Media on the Exhaust Fan and vent located in the back of the equipment. This is your first line of defense against airborne dust and debris. The Fan Filter Media is supplied with new Bulbs and should be changed regularly.
- B: Ideal operation of this equipment suggests at least 12" of clearance behind the unit for proper ventilation. Confirm that the Intake Fan is not feeding from the exhaust of other equipment.
- C: Confirm both Intake and Exhausts Fans are operating.
- D: Equipment may already be full of dust and debris, over heating the internal electronics.

SPARE PARTS

ITEM	PART#
Bulb/Reflector Assembly	38465
Fuses: F4.0 Amp	37869
Fan Filter and Holder	38587
Fan Filter Media	38659
Blue Lens and Nylon Spacer	38595 & 37176
Clip, Spring, Lower	39609
Clip, Reflector Upper (Teflon)	38548
Fan Assembly (including Thermistor)	38625
Feet (Rubber Bumper)	38572
Filter, Band-pass	35986
Harness to Hour Meter	40731
Hour Meter for BlueWave® 200 version 1.1 unit serial #s 5121800 and higher	40730
Igniter	38776
Filter, Dual Fuse IEC Inlet	37178
Power Supply, 200W PFC	38774
Footswitch	40402
Shutter	38544
Solenoid Assembly	38628
Switch, Manual Timer	35384
Switch, Power	36288
Switch, Reset Assembly	38807
Timer, Digital	36287
Board, Communication Assembly	38767
Board, Shutter Operation Assembly	38766

OPTIONS/ACCESSORIES:

ITEM	PART#
BlueWave Case with Foam	38679
Liquid-D Lightguide, 5 mm X 1 Meter	5720
Liquid-D Lightguide, 5 mm X 1.5 Meter	5721
Liquid-D Lightguide, 8 mm X 1 Meter	5722
Liquid-D Two Pole Lightguide, 3 mm X 1 Meter	38476
Liquid-D Three Pole Lightguide, 3 mm X 1 Meter	38477
Liquid-D Four Pole Lightguide, 3 mm X 1 Meter	38478
UV Goggles – Green	35286
UV Goggles – Gray	35285
Face Shield	35186
DYMAX ACCU-CAL™ 50 Radiometer	39560
Lightguide Simulator	38408

DEFINITION OF TERMS

Bulb - Light source generating ultraviolet, visible, and infrared radiant energy from burning matter stimulated by electrical power conditioned by a proper power supply which is an integral part of a Lamp. A light source is usually placed into a Reflector (of various geometry) to increase light source efficiency by collecting and directing radiant energy of selected spectra (for a given curing process).

Intensity - A measure of light energy over the unit of surface area (usually surface at the specified working distance from the bottom of Reflector Housing) in W/cm^2 or mW/cm^2 . For the UV portion of light, this measure is often called in literature "irradiance", i.e. radiant energy arriving at a point on a surface per unit area.

Brightness, also known as **Luminance** - Description of energy in the visible region of the spectrum (approximately from 400 to 700 nm) and recorded in photometric units. "**Intensity**" (see below) of visible light energy is called Luminance.

Luminance - Luminous flux (energy of visible light) incident per unit area, and measured in **Lx** (lux) or **Lumen/cm²**.

Ultraviolet (UV) - The invisible region of the spectrum just beyond the violet end of the visible region. Wavelength ranges in general from 1.0 to 400 nm. DYMAX bulbs (burners) do not radiate energy in deep ultraviolet; there are very minute amounts below 220 nm and practically nothing can be sensed below 200 nm. This is due to the use of ozone-blocking quartz Bulb Envelope (See Ozone).

1. **Ultraviolet A (UV-A)** - UV of long wavelength from within approximately 400 to 320 nm of the spectral band (4000 to 3200 \oplus) - predominately produced by DYMAX Flood Lamps.
2. **Ultraviolet B (UV-B)** - UV of medium wavelength from within approximately 320 to 280 nm - DYMAX Flood Lamps produce some amount of their energy within this bandwidth.
3. **Ultraviolet C (UV-C)** - UV of short wavelength below 280 nm (we say from 280 to 200 nm) – a large amount of this energy is present in the sunlight.
4. **Visible** - Light that can be seen 400 to 700 nm.

Dose - Irradiance integrated over time, or Irradiance (W/cm^2) x Time (s) = Dose (Joules/cm²). Note: Watt is the power that gives rise to the production of energy at the rate of 1-joule (J) per second (s).

Ozone - oxidizing agent (O₃) produced by the action of Ultraviolet radiant energy (below 185 nm) or electrical corona discharge of oxygen on air.

OSHA 1910.145: "Regulation of Accident prevention Signs and Tags" defines the following headers as:

WARNING - Used when there is a hazardous situation that has some probability of severe injury.

CAUTION - Used to indicate a hazardous situation that may result in minor or moderate injury.

NOTICE - Used to convey a message related directly or indirectly to the safety of personnel, or protection of property.

OSHA 1910.145: "Regulation de la prevention d'accident Signes et Étiquettes" défin les têtes comme:

AVERTISSEMENT - est utiliser quand il ya un situation hasardeux qu'il avais de probalilité de se blesser sévère.

PRE-CAUTION - est user pour indiquer un situation hasardeux qu'il peut être en consequence en minueur ou modère blessure.

ATTENTION - est user pour communiquer un message lié directement ou indirectement à la sécurité de personnel, ou protection de propriété.

WARRANTY

CAUTION!

DYMAX CORPORATION RESERVES THE RIGHT TO INVALIDATE ANY WARRANTIES, EXPRESSED OR IMPLIED, DUE TO ANY REPAIRS PERFORMED OR ATTEMPTED ON DYMAX EQUIPMENT WITHOUT WRITTEN AUTHORIZATION FROM DYMAX. THOSE CORRECTIVE ACTIONS LISTED BELOW ARE LIMITED TO THIS AUTHORIZATION.

DYMAX offers a one-year warranty against defects in material and workmanship on all system components, except the Bulb, *with proof of purchase date*. Unauthorized repair, modification, or improper use of equipment may void warranty. The use of aftermarket replacement parts not supplied or approved by DYMAX Corporation, will void any effective warranties and may result in damage to the equipment.

REPLACEMENT BULB WARRANTY

If the Bulb fails to ignite during the warranty period of 2,000 hours and all Bulb history cards for a specific BlueWave® 200 have been returned to DYMAX, the Bulb will be replaced under warranty. No other warranties are implied or expressed.

© 2006-2011 DYMAX Corporation. All rights reserved. All trademarks in this guide, except where noted, are the property of, or used under license by DYMAX Corporation, U.S.A.

Please note that most dispensing and curing system applications are unique. DYMAX does not warrant the fitness of the product for the intended application. Any warranty applicable to the product, its application and use is strictly limited to that contained in DYMAX's standard Conditions of Sale. DYMAX recommends that any intended application be evaluated and tested by the user to insure that desired performance criteria are satisfied. DYMAX is willing to assist users in their performance testing and evaluation by offering equipment trial rental and leasing programs to assist in such testing and evaluation. Data sheets are available for valve controllers or pressure pots upon request. MAN015 PN38820 4/25/2011

DYMAX Corporation
860.482.1010
info@dymax.com
www.dymax.com

DYMAX Europe GmbH
+49 (0) 611.962.7900
info_de@dymax.com
www.dymax.de

**DYMAX UV Adhesives &
Equipment (Shenzhen) Co Ltd**
+86.755.83485759
dymaxasia@dymax.com
www.dymax.com.cn

DYMAX Asia (Hong Kong) Ltd
+852.2460.7038
dymaxasia@dymax.com
www.dymax.com.cn

DYMAX Korea LLC
82.2.784.3434
info@dymax.kr
www.dymax.co.kr

