

Shutters

Manual Louvered & ZIP™ Shutters



Manual Louvered Shutter PN 35572

ZIP™ Shutter PN 37863

Operation Manual

TABLE OF CONTENTS

Unpacking and Inspection	Page 3
Safety Information.....	Page 4
General Information	Page 4
Specifications.....	Page 5
Components Description	Page 6
Installation and System Interconnect.....	Page 7-9
Operation	Page 10
ZIP™ Shutter Maintenance and Replacement	Page 11-12
Troubleshooting	Page 13
Spare Parts	Page 13
Definition of Terms.....	Page 14
Warranty Information	Page 15

Before shipping, your Shutter was thoroughly checked and tested for trouble-free performance. The proper set up and operation of this Shutter as a system with any DYMAX Flood Lamp and accessory will assure long, safe, and user-friendly performance, providing an optimum yield from your light-curing process.

THEREFORE WE ENCOURAGE YOU TO READ, UNDERSTAND, AND FOLLOW ALL SAFETY AND OPERATING INSTRUCTIONS AND RECOMMENDATIONS COMPILED IN THIS AND OTHER RELATED MANUALS prior to setting up and operating this new Flood Lamp System or its individual components. If you encounter a problem, have any questions, or would like to help us with your suggestions and recommendations, please contact our Application Engineering and Customer Service Departments.

UNPACKING AND INSPECTION

Upon receipt of the unit, carefully remove the contents from the boxes and check for damage. If the carton is visibly damaged, sign for it as “damaged” or “open” and request inspection by the carrier. If concealed damage is found, notify the carrier and the shipper.

Check the box for the contents listed below and write down the serial number for further reference. If the unit arrived accompanied with the other boxes, check the contents of each box.

Shutter Components		
Manual Louvered Shutter PN 35572		
 <p>Manual Shutter</p>	 <p>2000/1200 Fan</p>	 <p>2000/1200 Mounting Plates</p>
ZIP™ Shutter PN 37863		
 <p>ZIP™ Shutter</p>	 <p>2000/1200 Fan</p>	 <p>2000/1200 Mounting Plates</p>
 <p>Adapter Plug</p>	 <p>Foot Switch</p>	 <p>Reflector Cable</p>

NOTE: Report any shortages or concerns to DYMAX Corporation Customer Service.

Before continuing with unpacking and installation, please read the following chapters of this manual for safety recommendations and installation, running, and troubleshooting instructions.

SAFETY

DYMAX Shutters are designed to be used properly set up, with all components correctly connected, and operated in accordance with relevant instructions. The units' design was developed to maximize operator safety and minimize exposure to UV.

WARNING! Always observe safety requirements!

CAUTION! Always wear protective goggles or face shield when working near UV light!

SAFETY RECOMMENDATIONS:

- Use goggles or a face shield approved for UV protection to protect your eyes.
- Long-sleeved shirts or a lab coat are recommended to protect the arms and use of UV opaque gloves will protect the hands.

GENERAL INFORMATION

DYMAX Shutters were developed as an auxiliary device for use with DYMAX EC- and PC-Series Flood Lamp Systems to control the dose of UV light directed onto adhesives. DYMAX Shutters are designed for use with most DYMAX Flood Lamps. The Shutters have the same mounting and can be used interchangeably at the customer's choice depending on the application. DYMAX Shutters can be used as an integral part of the DYMAX Light Shield and can be used with other DYMAX Flood Lamps with the appropriate adapters.

DYMAX Flood Lamps use a medium-pressure arc Bulb as a source of UV light. The Bulb requires a few minutes to warm up after ignition before it reaches a steady state and needs a few minutes to cool before being able to ignite again after being turned off. Turning the Bulb off and on negatively affects the lifetime of the Bulb. With a DYMAX Shutter installed, the Flood Lamp may stay on continuously. Objects needing curing may be loaded and unloaded from underneath the Shutter when it is shut without exposing operators to UV light. In addition, control of curing times can be achieved by timed Shutter operation.

DYMAX Flood Lamp Systems are used for a wide variety of applications where a relatively large area of illumination is needed. These applications may be cured using one of two types of systems: the first is with continuous illumination in conveyorized curing systems where the dose is defined by the conveyor belt speed. The second type uses a free standing Flood Lamp where accurate timing is required. In the second type, the Shutter can ensure the proper dose.

DYMAX offers two shutter models: the Manual Louvered Shutter and the ZIP™ Shutter.

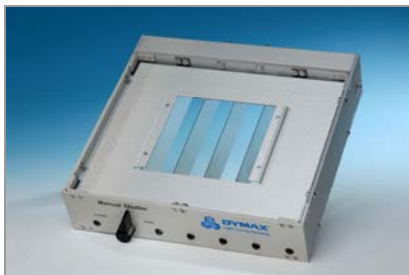

Figure 2. Manual Shutter PN 35572

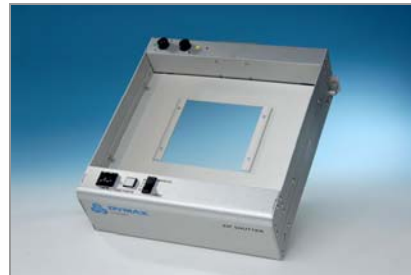

Figure 1. ZIP™ Shutter PN 37863

SPECIFICATIONS

Manual Shutter	
Dimensions, W x D x H	11.0" x 12.5" x 1.5" [27.9 cm x 31.8 cm x 3.8 cm]
Weight	3.5 lbs [1.6 kg]

ZIP™ Shutter (Clear Aperture)	
Operating Voltage	24 VDC (Supplied by the DYMAX EC or PC Power Supply)
Exposure Time	Digital Setting - From 1 to 99 Seconds
Aperture	6" x 8"
Operation Mode	Timed/Manual
Dimensions, W x D x H	11.0" x 12.5" x 3.5" [27.9 cm x 31.8 cm x 8.9 cm]
Weight	5.8 lbs [2.6 kg]

COMPONENTS DESCRIPTION

ZIP™ SHUTTER

The ZIP™ Shutter has a clear aperture; therefore there is no distraction of the light flow when the Shutter is open.

The operator sets the Shutter "Open Time" using a Digital Potentiometer (Timer) (1) on the top of the front control panel. The Digital Potentiometer is coupled with an electronic timer (inside the front panel) which in turn operates the gear-motor located inside the Front Control Panel. Shutter "Open Time" can be set from 1 to 99 seconds.

Depressing the Push Button Actuator (2) located on top of the Front Control Panel activates a gear-motor. The unit can also be actuated by foot pedal. The foot pedal can be connected to the Foot Pedal Connection (5) on top of the Rear Panel.

There are two operation modes available: timed and manual. Use the Rocker Switch (3) to select the mode of operation.

The power (24 V) to the ZIP™ Shutter comes directly from the Lamp Power Supply (see Figure 17) through the receptacle (4) on top of Rear Panel.

The ZIP™ Shutter includes two Reflector Housing Mounting Plates: one with a clear aperture of 5" x 5" for use with the 5000-EC Lamp, and a second with a clear aperture of 8" x 8" for use with the 2000-EC Lamp Reflector Housings.

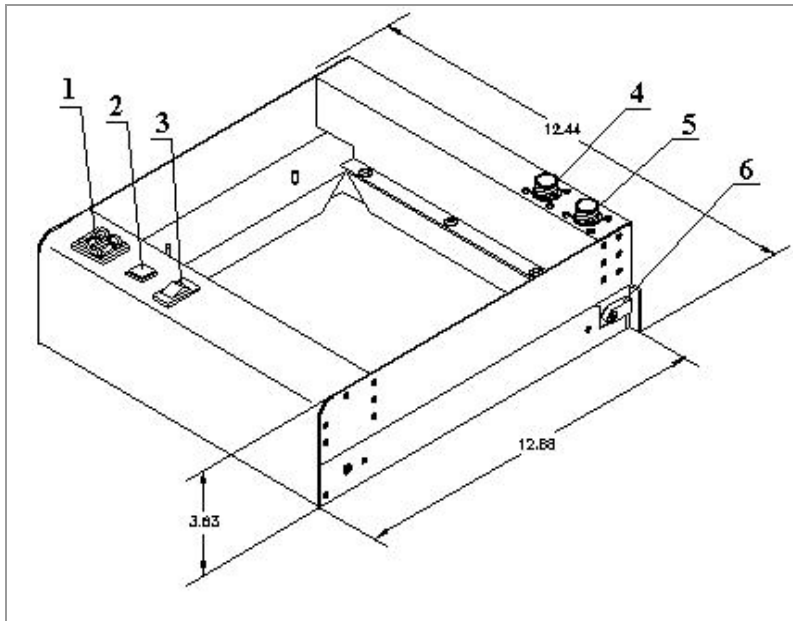

Figure 18. ZIP™ Shutter Component Diagram

ZIP™ Shutter Components	
#	Part
1	Potentiometer (Timer)
2	Push Button Actuator
3	Manual/Auto Mode Selector Switch
4	Cable from Reflector Connection
5	Foot Pedal Connection
6	Belt Tension Adjustment

INSTALLATION AND SYSTEM INTERCONNECT

NOTE: Setup of the EC- or PC-Series Flood Lamps are covered in the EC- or PC-Series operation manuals. Refer to MAN007 – EC-Series Flood Lamp Manual or MAN006 - PC Series Flood Lamp Manual.

MANUAL SHUTTER INSTALLATION

5000-EC or 5000-PC Flood Lamp:

1. Remove the Adapter Plate from the Manual Shutter by removing the four 8-32 x $\frac{3}{8}$ " screws (Figures 3 & 4).
2. Install the Adapter Plate on the base of the 5000-EC/PC Lamp Reflector Housing by removing the four 8-32 x $\frac{1}{4}$ " screws (Figure 3) and attaching the Adapter Plate to the Lamp Housing with four new 8-32 x $\frac{3}{8}$ " screws (Figure 5).
3. Install the assembly into the Manual Shutter and attach it with four 8-32 x $\frac{3}{8}$ " screws.

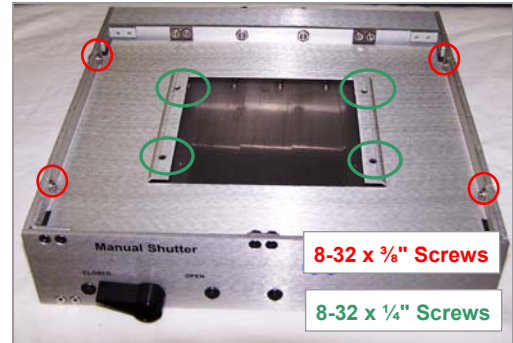

Figure 3. Manual Shutter with Adapter Plate Installed



Figure 4. Manual Shutter with Adapter Plate Removed

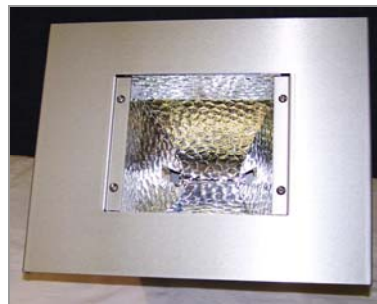

Figure 5. Flood Lamp with Adapter Plate Installed



Figure 6. Lamp Housing Assembly Installed in Manual Shutter

2000-EC, 1200-EC, or 1200-PC Flood Lamp:

1. Remove the Adapter Plate from the Manual Shutter by removing the four 8-32 x $\frac{3}{8}$ " screws (Figures 3 & 4).
2. Install the two Mounting Plates (Figure 7) on the 2000-EC/PC or 1200-EC/PC Lamp Reflector Housing by removing the four 6-32 x $\frac{1}{2}$ " screws and attaching the Mounting Plates to the Lamp Reflector Housing by reinstalling the four screws (Figure 8) removed in instruction one.
3. Install the assembly into the Manual Shutter and attach it with four 8-32 x $\frac{3}{8}$ " screws (Figure 9).

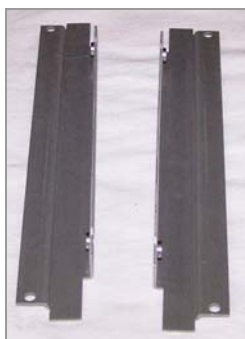

Figure 7. Mounting Plates



Figure 8. Bottom View of Lamp with Mounting Plates installed



Figure 9. Flood Lamp Assembly Installed into Manual Shutter

ZIP™ SHUTTER INSTALLATION

5000-EC or 5000-PC Flood Lamp

1. Remove the Adapter Plate from the ZIP™ Shutter by removing the four 8-32 x 3/8" screws (Figures 10 & 11).



Figure 10. ZIP™ Shutter



Figure 11. Adapter Plate Removed

2. Install the Adapter Plate on the base of the 5000-EC/PC Lamp Housing by removing the four 8-32 x 1/4" screws and attaching the plate to the Lamp Housing with four new 8-32 x 3/8" screws (Figure 12).
3. Install the Lamp Housing Assembly into the ZIP™ Shutter and attach it with four 8-32 x 3/8" screws (Figure 13).



Figure 12. ZIP™ Shutter with Adapter Plate Installed



Figure 13. 5000-EC Flood Lamp Assembly Installed on a ZIP™ Shutter

2000-EC Flood Lamp

1. Remove the Adapter Plate from the ZIP™ Shutter by removing the four 8-32 x 3/8" screws (Figure 10 & 11).
2. Install the two Mounting Plates (Figure 14) on the base of the 2000 EC/PC Lamp Housing by removing the four 6-32 x 1/2" screws and attaching the Mounting Plates to the Lamp Housing by reinstalling the screws (Figure 15).
3. Install the assembly into the Manual Shutter and attach it with four 8-32 x 3/8" screws (Figure 16).



Figure 14. Mounting Plates

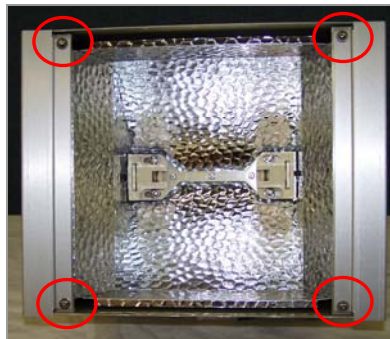

Figure 15. Bottom of Lamp Housing with Plates Installed



Figure 16. 2000-EC Lamp Housing Assembly Installed into ZIP™ Shutter

ZIP™ SHUTTER ELECTRICAL INTERCONNECT

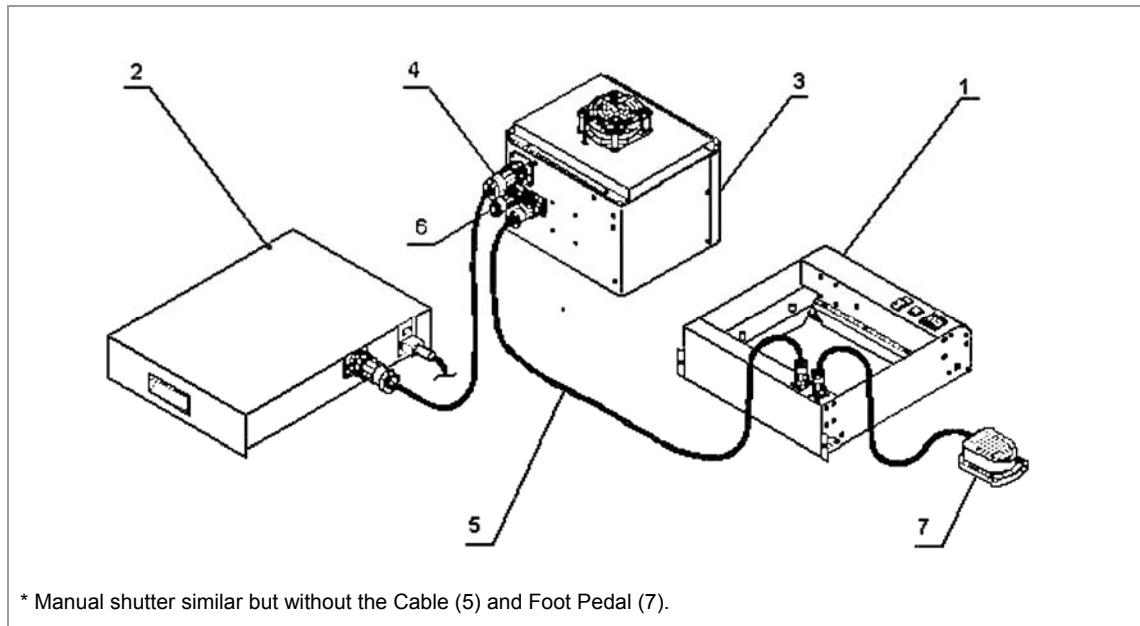

Figure 17. ZIP™ Shutter Electrical Interconnect Diagram*

#	Description	Part Number
1	ZIP™ Shutter, Optional	37863
2	Power Supply (8-Pin Connector)	Dependent on Flood Lamp System used
3	Reflector (8-Pin Connector)	Dependent on Flood Lamp System used
4	8-Pin to 8-Pin Interconnect Cable	37904
5	Shutter Interconnect Cable, Optional	38240
6	Plug, Adapter, Optional	38318
7	Foot Pedal, Optional	38992

1. Connect Shielded Cable (4) from J2 on rear of Power Supply (2) to J3 on rear of Reflector Housing (3).
 2. Connect Cable (5) from J4 on rear of Reflector (3) to 8-Pin Connector on rear of Shutter (1).
 3. Connect Plug (6) into J5 on rear of Reflector (3).
- NOTE:** Shutter will not operate unless Plug is installed.
4. Install Foot Pedal to 4-Pin Connector on rear of Shutter (7).
 5. Connect Power Cord to J1 on rear of Power Supply (2).

DYMAX FLOOD LAMP ELECTRICAL INTERCONNECT WITH RETROFIT

To retrofit Shutters for use with older DYMAX "Blue Series" Flood Lamps, please contact the DYMAX Applications Engineering or Equipment Group.

OPERATION

MANUAL LOUVERED SHUTTER OPERATION

- Have the Manual Shutter in the closed position.
- Open the Access Door to the DYMAX Light Shield and place the object to be cured on the work surface (preferably in line with the center of the Manual Shutter).
- Turn the Manual Shutter to the "Open" position.
- When the required curing time for the application has elapsed, turn the Knob to close the Manual Shutter and end the cycle.

ZIP™ SHUTTER OPERATION

- Have the ZIP™ Shutter in the closed position.
- Open the Access Door to the Workstation or DYMAX Light Shield and place the object to be cured on the work surface (preferably in line with the center of the Shutter).
NOTE: The ZIP™ Shutter will close automatically if the Light Shield has an Interlock Kit installed and the Access Door is opened.
- Adjust the distance from the bottom plane of the ZIP™ Shutter to the surface to be cured.
- Close the Access Door.
- Set the exposure (ZIP™ Shutter "Open Time") by adjusting +/- the digital Knob-Pot located next to the Actuate Button on the Front Panel.
- Open the ZIP™ Shutter using the most convenient method for you by using Push Actuator Button or Foot Pedal (see Page 9).
NOTE: The ZIP™ Shutter will close automatically in "Timed Mode" or will stay open until you release the Foot Pedal or switch in manual mode.
- Close the ZIP™ Shutter to end the cycle.

ZIP™ SHUTTER MAINTENANCE

CHECK AND ADJUST CURTAIN DRIVE-BELT TENSION

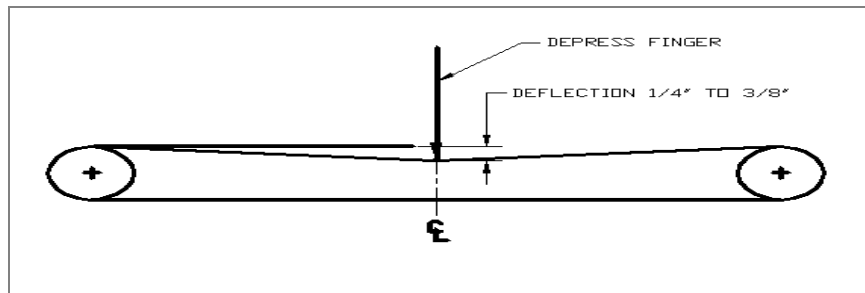

Figure 19. Belt Tension Adjustment

DYMAX recommends that the ZIP™ Shutter's Curtain Drive-Belt's tension be checked at least once every three months. To check the Curtain Drive-Belt's tension:

- Turn off and disconnect the Lamp Reflector Housing from the external AC source.
- Remove the ZIP™ Shutter from the Flood Lamp Reflector Housing and place it on the bench, bottom-side up.
- Remove the screws that attach the ZIP™ Shutter's bottom panel.
- Very lightly press in the center of the Curtain Drive Belt with a finger; the Belt should deflect no more than $\frac{1}{4}$ " to $\frac{3}{8}$ ".
- If deflection exceeds this value, tighten the Curtain Drive Belt by adjusting the Tension Screw in the back of the ZIP™ Shutter.
NOTE: Make sure that both belts are tightened equally.
- Replace the bottom cover and secure it with its screws.
- Place the ZIP™ Shutter back on the Flood Lamp Reflector Housing and re-position it.
- Reconnect the cables and plug the AC cord into wall socket.

ZIP™ SHUTTER CURTAIN ASSEMBLY REPLACEMENT

DYMAX recommends that you check the ZIP™ Shutter Curtain fabric for wear each time you change the Lamp. If it shows any signs of wear, replace it. Additional Curtain Assembly replacements can be purchased through DYMAX Customer Service.

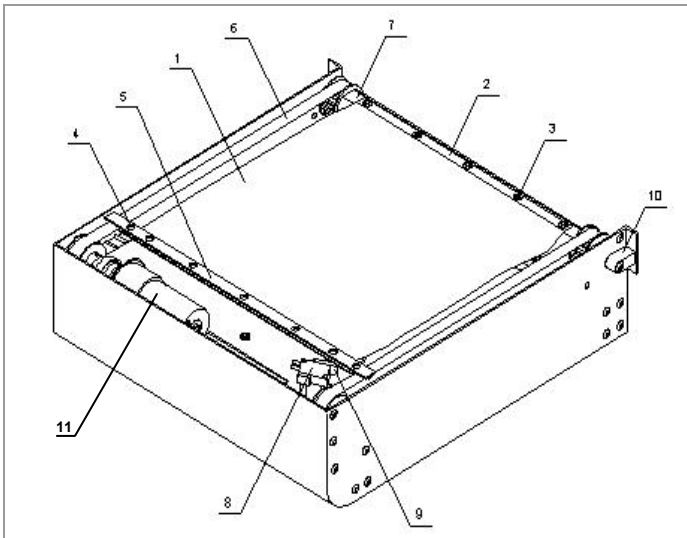

Figure 20. ZIP™ Curtain Assembly Diagram

Curtain Assembly	
#	Part
1	Curtain
2	Roller Bar
3	Screws (5)
4	Side Screws (2)
5	Clamp Bar
6	Belts
7	Roller and Pulley
8	Limit Switch
9	Limit Switch Standoff
10	Belt Tension
11	Belt Drive Motor

1. Remove the Flood Lamp Reflector Assembly from the ZIP™ Shutter and flip the Shutter onto its top.
2. Remove the bottom cover of the ZIP™ Shutter to expose the inside Roller (7) and Belt Drive Motor. Depending on which revision level your Shutter is, there will be either six screws or twenty six screws.
3. Manually unroll the Curtain (1) until the Curtain (1) reaches front Limit Switch (8).
4. Loosen the Belt (6) tension by unscrewing the rear screws.
5. Remove the old Curtain (1) by removing the five screws (3) on the Roller (7) and loosening the two Side Screws (4) on the Clamp Bar (5) and slide curtain off Belts (6).
6. Attach the new Curtain (1) to the Roller (7) and Roller Bar (2) with the 6-32 screw (3) previously removed from the Roller.
7. Stretch the new Curtain (1) toward front of ZIP™ Shutter.
8. Slide the Clamp Bar (5) onto the Belt (6) where Curtain is fully outstretched. The Curtain should be stretched short of front Limit Switch (8).
9. Tighten the end screws 4-40 (4).
10. Manually roll-up the Curtain until the Curtain reaches rear Limit Switch (8). If the Clamp Bar (5) bows, loosen the screws (4) and allow the Clamp Bar to find its natural straightness and retighten.
11. Replace the ZIP™ Shutter's bottom cover.
12. Set-up the ZIP™ Shutter according to the ZIP™ Shutter directions. Tighten the Belt Tension (10) as needed to improve Belt performance.

TROUBLESHOOTING

CAUTION: Only qualified maintenance personnel should attempt the following procedures.

Problem	Possible Cause	Testing	Corrective Action
Shutter Curtain Does Not Open or Close Smoothly	One of the tension screws is not tight enough	All functions of the ZIP™ Shutter operate properly	Adjust Curtain tension.
Motor Continues to Run	One of the Limit Switches is not engaging properly	All functions of the ZIP™ Shutter operate properly	Adjust the Micro-Switch Activating Blade.
Shutter Will Not Operate	No Power at Shutter	Verify the supply voltage being delivered to the Shutter. Test the voltage at Pins 1 & 2 of the 8-Pin Connector (24 VDC)	Check and replace wiring If light source is operational and ZIP™ Shutter is not. If a problem occurs within the light source, consult manual.
	Plug (PN 38317 or PN38318) not installed in J5 of Reflector Housing	All functions of the ZIP™ Shutter operate properly	Install plug as described in Installation Instructions.

SPARE PARTS

ZIP™ Shutter

Item	Part #
Timer Board, 0-100 Seconds	40315
Curtain (Assembly)	38071
Relay	37789
Motor	39395
Cable, Reflector Housing to Shutter	38240
Clutch	38340
Foot Pedal with Extended Cable	38992
Plug, Stand Adapter	38318

DEFINITION OF TERMS

UV Curing Light Source – arrangement of a Reflector Housing and a Power Supply furnished with an appropriate bulb (burner) for generating light energy of required spectra and intensity.

Flood Lamp System - set of components arranged to generate, collect, condition and direct UV radiant energy to perform curing of engineering adhesives, coatings, and inks in a safe and controlled process. It includes a Lamp Housing and Power Supply and may also include a Shutter, and Workstation, UV Enclosure, or DYMAX Lightshield, and accessories.

Lamp - light source (bulb or burner) generating Ultraviolet, Visible, and Infrared radiant energy from burning matter stimulated by electrical power. A bulb or burner is usually placed into a reflector to increase light source efficiency by collecting and directing radiant energy of selected spectra for a specific curing process.

Intensity - a measure of light energy over the unit of surface area (usually at a specified working distance from the bottom of a reflector housing) in W/cm^2 or mW/cm^2 . For the UV portion of light, this measure is often called in literature “irradiance”, i.e. radiant energy arriving at a point on a surface per unit area.

Brightness, also known as **Luminance** - description of energy in the visible region of the spectrum (approximately from 400 to 700 nm) and recorded in photometric units. “**Intensity**” (see below) of visible light energy is called luminance.

Luminance - luminous flux (energy of visible light) incident per unit area, and measured in **Lx** (lux) or **Lumen/cm²**.

Ultraviolet (UV) - the invisible region of the spectrum just beyond the violet end of the visible region. UV is divided into three spectral parts:

1. **Ultraviolet A (UV-A)** - UV of long wavelength from within approximately 400 to 320 nm of the spectral band (4000 to 3200Å) - predominately produced by DYMAX Flood Lamps.
2. **Ultraviolet B (UV-B)** - UV of medium wavelength from within approximately 320 to 280 nm - DYMAX Flood Lamps produce some amount of their energy within this bandwidth.
3. **Ultraviolet C (UV-C)** - UV of short wavelength below 280 nm (we say from 280 to 200 nm) – a large amount of this energy is present in the sunlight.

Dose - is irradiance integrated over time, or Irradiance (W/cm^2) x Time (s) = Dose (Joules/cm²). Note: Watt is the power that gives rise to the production of energy at the rate of 1-joule (J) per second (s).

As irradiance can be a far more significant factor in the efficiency of curing adhesives and other UV curable materials, the dose and spectral response can also be substantial contributors to the quality cure performance.

OSHA 1910.145: “Regulation of Accident prevention Signs and Tags” defines the following headers as:

WARNING – is used when there is a hazardous situation that has some probability of severe injury.

CAUTION - is used to indicate a hazardous situation that may result in minor or moderate injury.

NOTICE - is used to convey a message related directly or indirectly to the safety of personnel, or protection of property.

WARRANTY

CAUTION!

DYMAX CORPORATION RESERVES THE RIGHT TO INVALIDATE ANY WARRANTIES, EXPRESSED OR IMPLIED, DUE TO ANY REPAIRS PERFORMED OR ATTEMPTED ON DYMAX EQUIPMENT WITHOUT WRITTEN AUTHORIZATION FROM DYMAX. THOSE CORRECTIVE ACTIONS LISTED BELOW ARE LIMITED TO THIS AUTHORIZATION.

DYMAX offers a one-year warranty against defects in material and workmanship on all system components *with proof of purchase date*. Unauthorized repair, modification, or improper use of equipment may void warranty. The use of aftermarket replacement parts not supplied or approved by DYMAX Corporation, will void any effective warranties and may result in damage to the equipment.

For further assistance with equipment, contact DYMAX Applications Engineering.



In the U.S. Call: 877.396.2963
In North and South America Call: +1.860.482.1010
In Europe Call: +49 (0) 611.962.7900
In China Call: +86.755.83485759
In Asia Call: +852.2460.7038
In Korea Call: 82.2.784.3434

www.dymax.com ♦ www.dymax.de ♦ www.dymax.com.cn ♦ www.dymax.co.kr

DYMAX Corporation - 318 Industrial Lane - Torrington, CT 06790 - Phone: 860.482.1010 - Fax: 860.496.0608 - E-mail: info@dymax.com - www.dymax.com

DYMAX Europe GmbH - Kasteler Strasse 45 - Building G 359 - 65203 Wiesbaden, Germany - Phone: +49 (0) 611.962.7900 - Fax: +49 (0) 611.962.9440 - E-mail: info_de@dymax.com - www.dymax.de

DYMAX UV Adhesives & Equipment (S.Z.) Co Ltd - Room 617 & 618, South Tower, Cangsong Building, Terra 6th Road, Futian District, Shenzhen, China 518040 - Phone: +86.755.83485759 - Fax: +86.755.83485760 - E-mail: dymaxasia@dymax.com - www.dymax.com.cn

DYMAX Asia (H.K.) Ltd - Flat B, 9/F, Yeung Yiu Chung (No. 8) Ind. Bldg., No. 20 Wang Hoi Road, Kowloon Bay, Kowloon, Hong Kong - Phone: +852.2460.7038 - Fax: +852.2460.7017 - E-mail: dymaxasia@dymax.com - www.dymax.com.cn

DYMAX Korea LLC - #903, CCMM B/D, 12 Yeoido-Dong, Youngdungpo-Gu, Seoul, Korea, 150-869 - Phone: 82.2.784.3434 - Fax: 82.2.784.5775 - E-mail: info@dymax.kr - www.dymax.co.kr

© 2006-2011 DYMAX Corporation. All rights reserved. All trademarks in this guide, except where noted, are the property of, or used under license by DYMAX Corporation, U.S.A. Please note that most dispensing and curing system applications are unique. DYMAX does not warrant the fitness of the product for the intended application. Any warranty applicable to the product, its application and use is strictly limited to that contained in DYMAX's standard Conditions of Sale. DYMAX recommends that any intended application be evaluated and tested by the user to insure that desired performance criteria are satisfied. DYMAX is willing to assist users in their performance testing and evaluation by offering equipment trial rental and leasing programs to assist in such testing and evaluation. Data sheets are available for valve controllers or pressure pots upon request. MAN010 PN 37771 6/06/2011