

Silver EC Series

UV Light-Curing Flood Lamp Systems

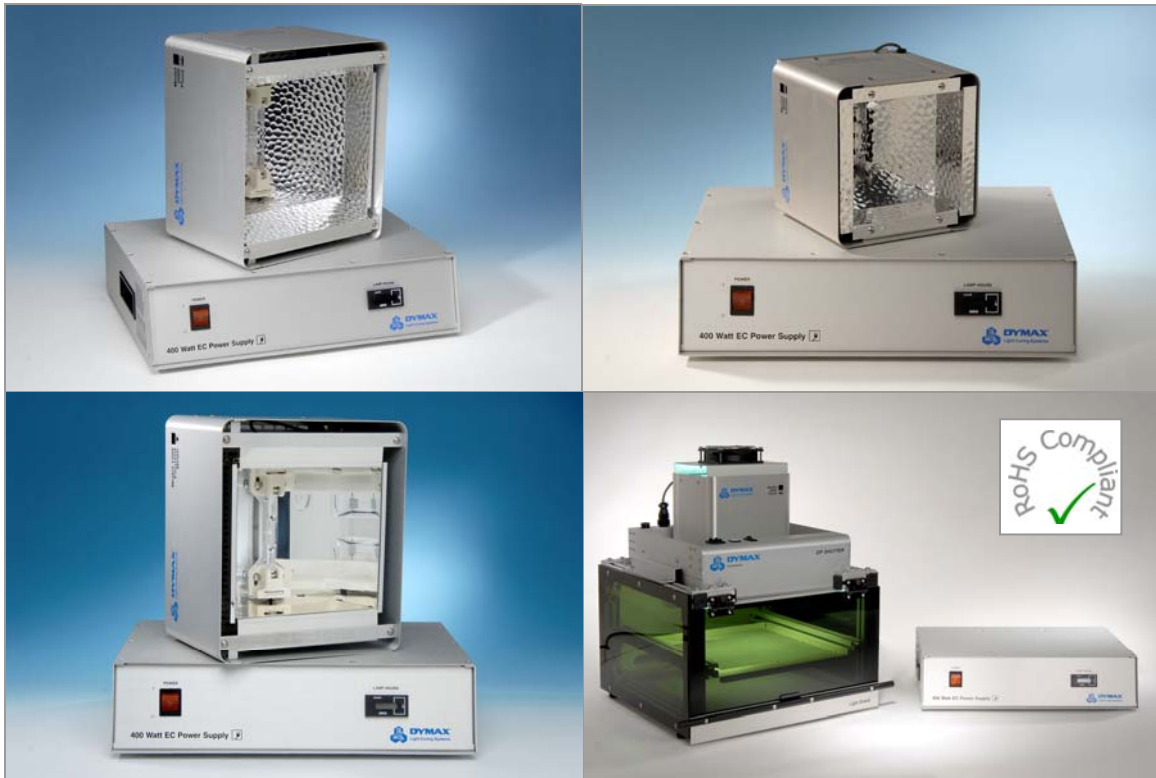

Clockwise from top left: 2000-EC Lamp, 5000-EC Lamp, Complete EC-Series Flood System, 1200-EC Lamp

Operation Manual

TABLE OF CONTENTS

Unpacking and Inspection	Page 3
Safety	Page 4-5
Description	Page 6-7
System Components Description	Page 7
Specifications	Page 7-9
Installation and System Interconnect.....	Page 10-11
Operation	Page 11
Maintenance	Page 12-14
Troubleshooting	Page 15
Spare Parts & Accessories	Page 16-17
Definition of Terms.....	Page 18
Warranty	Page 19

The enclosed DYMAX EC-Series UV Light-Curing Flood Lamp System was developed and manufactured by the DYMAX team, driven by a desire to best serve your needs. Before shipping, your EC-Series Flood Lamp System was thoroughly checked and tested for trouble-free performance.

The proper set up and operation of this Flood Lamp System will maximize safety and user-friendly performance, providing optimum yield of your technological process.

THEREFORE, WE ENCOURAGE YOU TO READ, UNDERSTAND, AND FOLLOW ALL SAFETY AND OPERATING INSTRUCTIONS AND RECOMMENDATIONS COMPILED IN THIS AND OTHER RELATED MANUALS prior to setting up and operating this new Flood Lamp System or its individual components.

If you encounter a problem, have any questions, or would like to help us with your suggestions or recommendations, please contact our Technical or Customer Service Departments.

UNPACKING AND INSPECTION

Upon receipt of the unit, carefully remove the contents from the boxes and check for damage. DYMAX is not responsible for damage from shipping – all claims for shipping damage should be made with the carrier.

Check all boxes for contents and write down any serial numbers for further reference. You may wish to retain original shipping cartons in case you need to repackage any item for return.

If you observe or experience any problem with your equipment, notify DYMAX Customer Service, your authorized distributor, or your DYMAX Representative immediately.

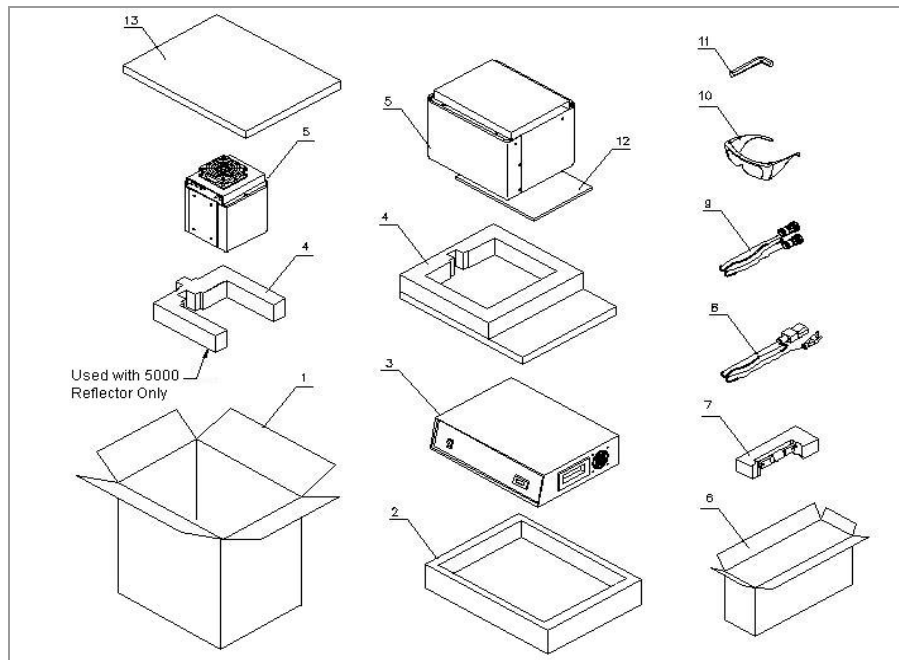

Figure 1. EC-Series Flood Lamp System Unpacking Diagram

#	Part
1	Box
2	Foam, Bottom
3	EC Power Supply
4	Foam, Middle
5	2000, 1200, or 5000 Reflector Housing
6	Box, Accessory
7	400 Watt Bulb
8	Power Cord
9	Interconnect Cable, CE
10	Goggles
11	Wrench
12	Optional Filter
13	Foam, Top

NOTE: REPORT ANY SHORTAGE TO DYMAX CUSTOMER SERVICE

Before continuing with unpacking and installation, please read the following chapters of this manual for safety recommendations and installation, operation, and troubleshooting instructions.

SAFETY

DYMAX UV light-curing technology has been used successfully for over 30 years. The fast cure, one-component nature of our UV light-curing technology has made it the process of choice for many manufacturers requiring a "cure on demand" assembly process. The purpose of this document is to provide information relating to the use of DYMAX UV light-curing systems. There are four common questions/concerns related to UV light-curing systems: UV exposure, high-temperature surfaces, ozone, and bright, visible light.

UV EXPOSURE

Standard DYMAX UV light-curing systems and bulbs have been designed to primarily emit UVA light (as shown in Chart 1). UVA light is generally considered the safest of the three UV ranges: UVA, UVB, and UVC. Although OSHA does not currently regulate ultraviolet light exposure in the workplace, the American Conference of Governmental Industrial Hygienists (ACGIH) does recommend Threshold Limit Values (TLV's) for ultraviolet light. The strictest interpretation of the TLV (over the UVA range) for workers' eyes and skin is 1 mW/cm² (intensity), continuous exposure. Unless workers are placing bare hands into the curing area, it is unusual to exceed these limits. To put 1 mW/cm² limit into perspective, cloudless summer days in Connecticut regularly exceed 3 mW/cm² of UVA light and also include the more dangerous UVB light (primarily responsible for sun tans, sun burns and skin cancer) as well.

The human eye can not detect UV energy, only visible light. A radiometer should be used to measure stray UV energy to confirm the safety of a UV light-curing process. A workstation that exposes an operator to more than 1 mW/cm² of UVA energy continuously should be redesigned.

Curing of UV light-curable chemistry can be a regulatory compliant, "worker-friendly" manufacturing process when the proper safety equipment and operator training is utilized. There are two ways to protect operators from UV exposure: shield the operator and/or shield the source.

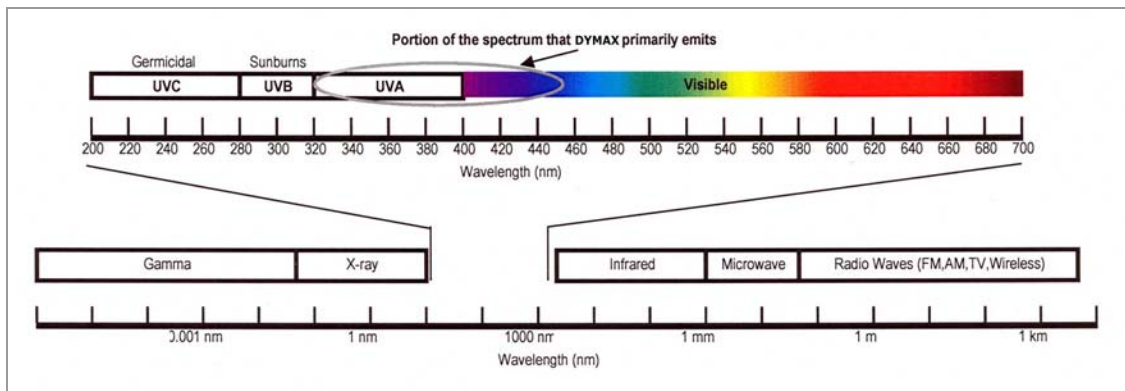

Chart 1. Spectrum of Light

SHIELD THE OPERATOR

- **UV-Blocking Eye Protection** – UV-blocking eye protection is recommended when operating UV light-curing systems. Both clear and tinted UV-blocking eye protection is available from DYMAX.
- **UV-Blocking Skin Protection** – Where the potential exists for UV exposure upon skin, opaque, UV-blocking clothing, gloves, and full-face shields are recommended.

SHIELD THE SOURCE OF UV

Any substrate that blocks UV light can be used as a shield to protect workers from stray UV light. The following materials can be used to create simple shielding structures or blind corners:

- **Sheet Metal** – Aluminum, steel, stainless steel, etc. Sheet metal should be coated black or black anodized to minimize reflection of UV and visible light toward operators.
- **Rigid Plastic Film** – Transparent, UV-blocking plastics (typically polycarbonate or acrylic) are commonly used to create shielding where transparency is also desired. These rigid plastic films are available either water-clear or tinted.
- **Flexible Film** – UV-blocking, flexible urethane films can be used to quickly create workstation shielding. This UV-blocking, flexible urethane film is available from DYMAX.

HIGH-TEMPERATURE SURFACES

Surfaces exposed to high-intensity curing lights will rise in temperature. The intensity, distance, exposure time, cooling fans, and the type/color of the surface can all affect the actual surface temperature. In some cases, exposed surfaces can reach temperatures capable of producing a burn or causing damage to a substrate. In these cases, care must be taken to ensure either a more moderate surface temperature or appropriate protection/training for operators.

OZONE

Standard DYMAX bulbs (UVA type) generate an insignificant amount of UVC and therefore essentially no ozone. Some UV light-curing systems, like those used to cure UV inks, emit primarily “shortwave” (UVB and UVC) energy. Upon exposure to UVC light (specifically <240 nm), oxygen molecules (O₂) split into oxygen atoms (O) and recombine with O₂ to create ozone O₃. The current, long-term ozone concentration limit recommended by ACGIH, NIOSH, and OSHA is 0.1 ppm (0.2mg/m³).

BRIGHT, VISIBLE LIGHT

The bright, visible light emitted by some UV light-curing systems can be objectionable to some workers and can cause eyestrain. Tinted eye protection and/or opaque/tinted shielding can be utilized to address this concern.

SUMMARY

UV light sources can be more “worker friendly” than many commonly accepted industrial processes, provided the potential concerns are addressed. Contact your DYMAX representative for information regarding the proper use of DYMAX UV light-curing systems.

DESCRIPTION

DYMAX EC-Series UV Light-Curing Flood Lamps are general-purpose units for the curing of UV light-curable adhesives, coatings, and inks. They have extensive use in a wide variety of applications such as bonding, potting, sealing, and encapsulating. These light sources are extremely unique in that they offer exceptional versatility and expandability.

The design of these units has been carefully considered to allow the light source to be successfully utilized in a wide variety of manufacturing situations. Further versatility is found in the ability to be configured in a wide variety of production situations.

Each unit is designed and shipped in a unitized configuration for easy bench-top mounting with all controls and functions right at the hands of the operator. Side mounted handles are installed in the Power Supply Housing for portability.

Each unit can also be custom configured for mounting of the Lamp/Reflector Assembly Housing in a remote curing location and the Power Supply can be mounted several feet away within the easy reach of an operator. The Lamp/Reflector Assembly Housings have been designed with clean, unobstructed surfaces for maximum ease of installation in existing or specialized equipment.

Several Lamp/Reflector Assembly Housings can be mounted side-by-side in a linear configuration (such as on conveyORIZED systems) or a large area array. The Power Supplies can then be stacked and mounted remotely to provide consolidated operator control.



Figure 2. Complete EC-Series Flood Lamp System



Figure 3. Lamp/Reflector Housings (5000-EC, 2000-EC, & 1200-EC)



Figure 4. EC-Series Power Supply

SYSTEM COMPONENTS DESCRIPTION

1200-EC:

The DYMAX 1200-EC is a focused-beam UV Light-Curing Lamp used for the curing of UV light-curable adhesives, coatings, and inks. The unit's elliptical Reflector provides an intense 1" x 6" area of UV energy 4.5" away from the lower edge of the Lamp/Reflector Assembly Housing.

The 1200-EC employs convection cooling. An optional Fan Ventilation Kit is available to remove excessive heat and ventilate curing vapors away from the Lamp/Reflector Assembly Housing. Refer to the spare parts/options section of this manual for more information on the Fan Ventilation Kit.

2000-EC:

The DYMAX 2000-EC is a general purpose UV Light-Curing Flood Lamp with an effective curing area of approximately 8" x 8", making it ideal for batch processing or curing large areas.

An optional special Glass UV Filter may be installed in the 2000-EC Reflector to reduce UV-B and UV-C spectral emissions. When operated correctly using the Glass UV Filter, extensive shielding associated with many Lamps can be minimized.

The 2000-EC employs convection cooling. An optional Fan Ventilation Kit is also available. This kit removes excessive heat due to the Lamp's possible proximity to other heat sources, or to remove vapors from under the Lamp/Reflector Assembly Housing during curing of UV light-curable materials. Refer to the spare parts/options section of this manual for more information on the Fan Ventilation Kit.

5000-EC:

The DYMAX 5000-EC is a general purpose UV Light-Curing Flood Lamp with an effective curing area of approximately 5" x 5". The unit is ideal for small batch processing of UV adhesives and potting compounds.

Comparatively, it provides more than twice the output intensity of a 2000-EC Flood Lamp for faster curing capability and the additional ability to cure conformal coating resins.

SPECIFICATIONS

GENERAL

Each unit consists of the following components:

- A Solid-State Power Supply that allows external electrical inputs and provides power to the Lamp located in the Lamp/Reflector Assembly Housing. The Power Supply contains the ON/OFF Power Switch and Hour Meter that are located on the left side of the front panel. The Power Supply also houses its own Cooling Fan and power distribution for optional accessories. The rear panel has an integrally fused AC-Power Receptacle and an 8-pin female Amp Connector.
- The Solid-State Power Supply yields reliable and stabilized Lamp voltage in virtually any electrical system in the world. Other than ensuring a properly configured plug is employed, no other adjustment of settings is required. The Power Supply also conditions the electrical power to the Lamp providing longer, more reliable Lamp life.
- A Lamp/Reflector Assembly Housing (refer to drawing on specific models) which contains the Reflector, UV Lamp, Lamp Sockets, high-voltage Starter and three circular connectors.
- Interconnect Cable between the Power Supply and Lamp/Reflector Assembly Housing.
- One Power Cord.

- One (1) pair of UV safety goggles.
- 400 Watt, Metal Halide (optional visible or mercury vapor) UV Bulb.
- EC-Series Flood Lamps are RoHS compliant.

GENERAL SPECIFICATIONS:

The Power Supply is designed for use as follows:

ELECTRICAL SPECIFICATIONS	
Power Output Range	Set at 395 Watts during manufacture
Operating Temperature, °C	0-50
Storage Temperature, °C	-20 to 80
Operating Humidity	0-90% (non condensing)
Main Voltage	90-264 VAC
Line Frequency	47-63 Hz
Current Consumption (max)	@115 VAC 8A @ 230VAC 4A
Inrush Current (max)	30A
Electrical Regulation	+/- 2.5% for effects of load, line, temperature
Output Protection	Short circuit and overload protected
Auxiliary DC Outputs	+24V, 1 A available for Lamp Housing Fan and Shutters +/-24V, ~0.5A and +6V unregulated
Bulb	400 Watt, metal halide (standard) 400 Watt, mercury vapor (optional) 400 Watt, visible (optional)

PHYSICAL	
Overall Unit Dimensions, approx. (W x D X H)	16" x 12" x 19" [40.6 cm x 30.5 cm x 48.3 cm]
Power Supply Dimensions, approx. (W x D X H)	16" x 12" x 4.25" [40.6 cm x 30.5 cm x 10.8 cm]
Bulb Life	2,000 hours (warranted)
Hour Meter	99,999.9 hours (non-resettable)

BULB SPECTRAL INFORMATION

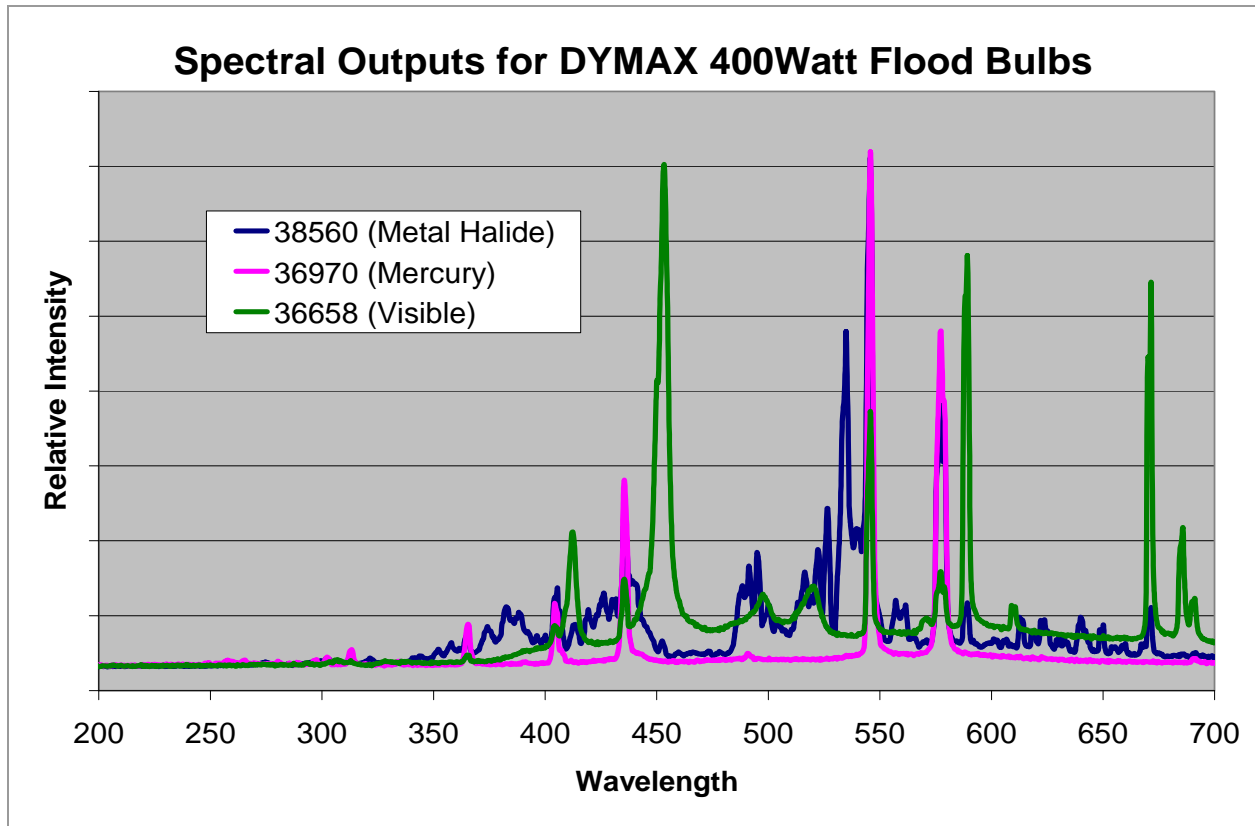





Figure 5. Spectral Outputs for a DYMAX 400W Flood Bulb

	1200-EC	2000-EC	5000-EC
			
Electrical	See General Specifications		
Dimensions	10.5" W x 9.0" D x 7.5" H [26.7 cm x 22.9 cm x 19.1 cm]	10.5" W x 9.0" D x 7.5" H [26.7 cm x 22.9 cm x 19.1 cm]	6.75" W x 6.75" D x 8.0" H [17.2 cm x 17.2 cm x 20.3 cm]
Weight	3.4 lbs. [1.5 kg]	3.4 lbs. [1.5 kg]	2.7 lbs. [1.2 kg]
Physical	See General Specifications		
Typical Initial Output Intensity at UV-A* (365 nm)	400 mW/cm ²	105 mW/cm ²	225 mW/cm ²

* 1200-EC: Intensity 4.5" from bottom edge of lamp/reflector assembly housing with the beam focused; 5000-EC: Intensity 3" below bottom edge of lamp/reflector assembly housing. All measured with an ACCU-CAL™ 50 UV Radiometer calibrated and traceable to NIST.

INSTALLATION AND SYSTEM INTERCONNECT

The only tool required for this procedure is 3/32 hex wrench which is provided with the unit.

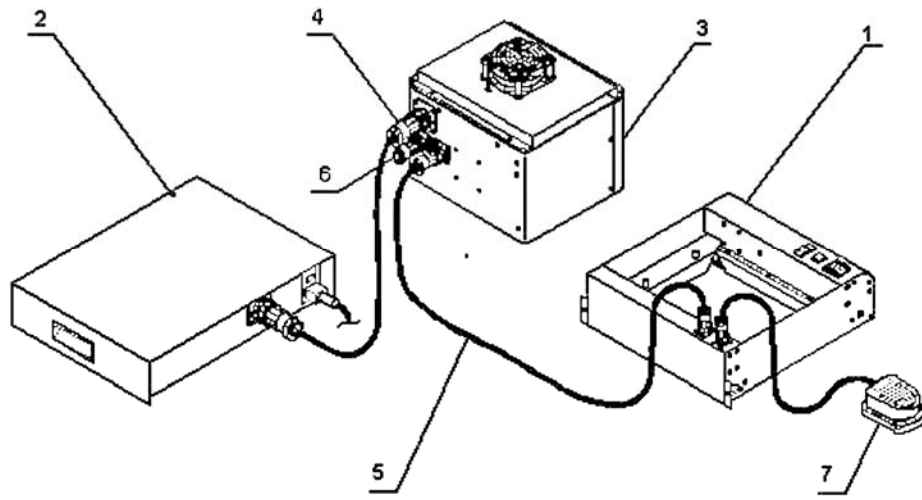

Figure 6. Interconnection Diagram

#	Part Description	#	Part Description
1	Shutter, Optional	5	Shutter Interconnect Cable, Optional
2	Power Supply (8-Pin Connector)	6	Plug, Adapter, Optional
3	Reflector (8-Pin Connector)	7	Foot Pedal, Optional
4	8-Pin to 8-Pin Interconnect Cable		

- Place the 400 Watt Bulb into the Lamp/Reflector Assembly Housing. Refer to the Bulb Replacement/Installation section of this manual.
- A Glass UV Filter is available as an option. This Glass UV Filter reduces heat produced by Lamp but will also reduce UV output of Reflector. To install the optional Glass UV Filter (sold only for the 2000-EC Flood Lamp):

NOTICE: It is important to wear protective gloves when installing the Glass UV Filter! Do not touch the Filter with bare fingers! Fingerprints may etch into glass and cause light transmission loss!

- Place the Reflector Housing up-side down on a flat surface.
 - Loosen the four screws in the bracket that hold the Reflector to the Housing.
 - Slide the Glass UV Filter under the brackets and adjust it symmetrically over the Reflector Aperture.
 - Tighten the four screws.
- Locate the Power Supply and Reflector Housing so that there is free air circulation around sides. The Reflector may be mounted to a DYMAX Flood Lamp accessory such as a Mounting Stand, Lightshield, or Shutter. See the connecting instructions in the operation manual for the appropriate DYMAX accessory.

WARNING! Always observe safety requirements when working with electrical equipment! Electrical hazard is present!

- Secure the Reflector Housing in the designated operation location.

5. Connect the Interconnect Cable to the J3 Receptacle on the Reflector Housing (coded red, Figure 7).

NOTE: Cables and receptacles are coded with color dots to assist in the installation of cables. Connections may vary if using a DYMAX Flood Lamp accessory such as a Mounting Stand, Light Shield, or Shutter. See the connecting instruction in the operation manual for the appropriate DYMAX accessory.

6. Connect the opposite end of the Interconnect Cable to the Lamp Power Receptacle on rear panel of the Power Supply (coded red).
7. Make sure that the other DYMAX accessories, if any, are also properly connected and operational.
8. Plug the Power Cord into the Power Module located in the rear panel of the Power Supply (Figure 8) and plug the other end of the Power Cord into an external AC source.



Figure 7. J3 Receptacle



Figure 8. Power Module

OPERATION

Turn the unit on by pressing on the Power Switch (located to the left on front of the Power Supply panel). The switch will light up to indicate that the power is on.

NOTE: While most Lamps typically require less than 30 seconds to ignite, a new Lamp will sometimes require several minutes.

After the Lamp has ignited, allow five minutes for the Lamp to reach its maximum output intensity.

Lamp life is reduced approximately one hour each time it is started. To avoid premature Lamp deterioration, leave the unit on through breaks, short shutdowns, and lunch hours.

These UV Flood Lamps are designed for continuous operation.

NOTE: If the power is momentarily lost or the Lamp is inadvertently shut off, it must cool down before restarting. This may take 5-10 minutes depending on ambient conditions. The Power Supply may be left energized while the Lamp is cooling. The Lamp will re-light when it has cooled sufficiently.

Each time the Lamp is turned on, it should operate for at least five minutes to allow complete ionization of elements inside the Lamp. Failure to do this may result in failure of the Lamp to restart. Refer to the troubleshooting section of this manual for more information.

MAINTENANCE

BULB REPLACEMENT PROCEDURE

Every new 400 Watt EC-Series UV Light-Curing Flood Lamp is supplied with a new Bulb. When the Bulb requires replacement, the following procedure must be followed:

Step 1. Turn the Power Switch off and disconnect the Power Supply from the electrical power source. Allow the Bulb to cool.

CAUTION: The Bulb operates at temperatures exceeding 500°C. Touching the Bulb before sufficient cool down time is allowed will cause severe burns. Always wear safety eye wear while replacing Bulb.

Step 2. Hold the Lamp/Reflector Assembly Housing securely and loosen the thumbscrew on the Lamp/Reflector Assembly Housing Bracket. Lift the housing off the Mounting Stand and place upside down on a clean work surface.

Step 3. Remove the Glass UV Filter (if installed in the 2000-EC) by removing one Retaining Strap held by two (2) 8-32 x 3/8" button-head screws with a 3/32 hex wrench. If the optional Glass UV Filter is installed, loosen the two (2) 8-32 x 3/8" button-head screws in the remaining Retainer Strap so that the Glass UV Filter can slide out.

Step 4. Reach into the Reflector and grasp the flat area of Bulb at either end.

CAUTION: Always use a soft, clean rag, clean paper towel, or gloves when handling the Bulb. Skin oils left on the Bulb will burn into the quartz, reducing output intensity. If the Bulb is inadvertently touched, clean the Bulb thoroughly with a soft, clean rag and alcohol.

Step 5. Lightly push the Bulb toward the Socket on the opposite end of the Lamp (Figure 10) so that the end being grasped can be lifted clear of the Socket (Figure 11).

Step 6. Install the new Bulb by following Steps 5, 6 and 7 in the reverse order.

IMPORTANT: Install the Bulb such that the seal dimple on the bulge of the glass is facing towards the Reflector surface. Avoid touching the quartz tube with your fingers.

NOTE: Bulb has no polarity.

Step 7. Record the serial number of the unit and the hour-meter reading in the Bulb History Record.

Step 8. Replace the Lamp/Reflector Assembly Housing on the Mounting Stand by engaging the Mounting Bracket.

Step 9. Secure the thumbscrew when the Lamp/Reflector Assembly Housing is at the proper height.

Step 10. Reconnect the Power Cord to the appropriate power source.

Step 11. Turn the Power Switch on and allow the Lamp to warm up for five minutes before using.

NOTE: If the Lamp does not ignite, refer to the trouble-shooting section of this manual.

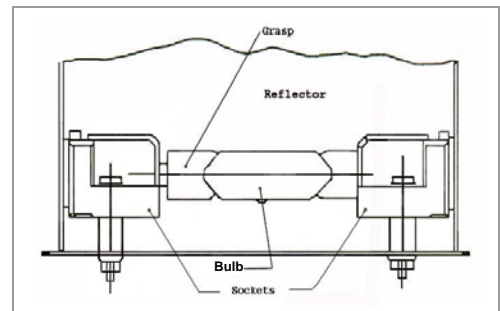

Figure 9. Bulb in Reflector

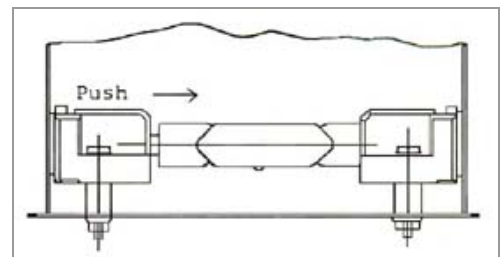

Figure 10. Push Bulb Towards Socket

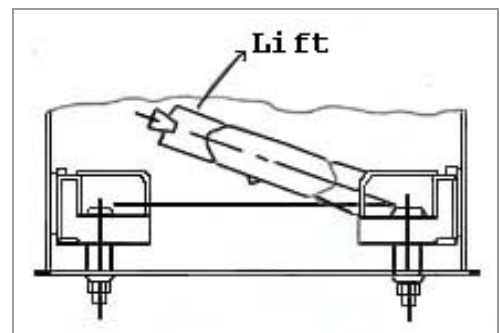

Figure 11. Lift Bulb

LAMP BASE REPLACEMENT KIT

Installation Instructions:

1. Turn off the power.
2. Remove the Power Cord and Interconnect Cord from the unit.
3. Remove the Lamp/Reflector Assembly from the Mounting Stand and place it on a clean, flat surface with the Lamp facing up.
4. Remove the Lamp (refer to Lamp Replacement Procedure).
5. Remove the Lamp/Reflector Assembly from the housing by removing the four screws, two on each side, from the Reflector.
6. Remove the two screws, from the side of the unit, holding the Igniter in place (located inside a blue fireproof sleeve) and remove from the sleeve.
7. Loosen the screws and remove the wires from the Igniter at locations marked "N" and "La".
 - a. The black Teflon wire at location "N" will have to be clipped from the Lamp Base Wire and re-stripped.
8. Remove both Lamp Bases and install the new Lamp Bases from the Lamp Base Replacement Kit.
9. Take one of the Lamp Bases and crimp on a supplied terminal (PN 35202). This wire will be installed in the "La" location on the Igniter.
10. The remaining Lamp Base Wire will be joined with the black Teflon wire using the supplied terminal (PN 35218). This wire will be installed in the "N" location on the Igniter.
11. Place the Igniter back into the blue fireproof sleeve and fasten to the side of the Housing using the two screws that had been removed in Step 6.
12. Place the Reflector back into the Housing and fasten with the four remaining screws.
13. Place the Lamp back into the unit.

FUSE REPLACEMENT PROCEDURE

The EC-Series 400 Watt Power Supply utilizes two Line-Input Fuses. These Fuses are external and are located in the Power Cord Receptacle at the rear of the Power Supply Housing. The Fuses are 6.25 Amp, slow-blow Fuses.

WARNING: Electrical shock hazard. Exercise extreme care when replacing Fuses. Make sure only qualified personnel perform Fuse replacement and that all power switches are off and the power cord is unplugged.

Replacing External Fuses:

1. Turn the Power Switch on the Power Supply off.
2. Unplug the Power Cord from the electrical source.
3. Unplug the Power Cord from the Power Cord Receptacle at the rear of the Power Supply Housing.

- Place a small, flat-blade screwdriver into the notch at the top of the Plug Recess and pull the Fuse Cover downwards approximately 70 degrees. The Fuse Retainer should be exposed and should be removed by pulling it straight out (see Figures 12-14).



Figure 12-14. Replacing Fuses

- Slide out the blown Fuses and replace with new 6.25 Amp, slow-blow Fuses.
CAUTION: It is important to replace this Fuse with the same 6.25 Amp rated, slow-blow type.
- Slide the Fuse Holder back into the Receptacle until it is fully seated, then rotate the cover upward until it latches.
- Install the Power Cord and connect it to the electrical power source.
- Turn the Power Switch on.

CLEANING:

Periodically remove and clean the optional Glass UV Filter if installed. Follow Step 5 in the Bulb Replacement Procedure for removal. Clean with any standard glass cleaner or use isopropyl alcohol for heavy deposits. Reinstall the Glass UV Filter by following Step 2 of the Installation Procedure.

NOTE: The optional Glass UV Filter for the 2000-EC loses its ability to transmit UV over time. This is due to “solarization” of the glass caused by the intense UV radiation. Cleaning can extend the useful life of the Filter, but its transmission should be monitored periodically and replaced as necessary.

Failure to regularly clean the Glass UV Filter will result in reduced UV output to the resin being cured, thereby increasing the time required to achieve optimum cure.

Periodically clean the Bulb and Reflector surfaces. A soft, clean cloth and any standard glass cleaner should be used. Heavier deposits may require cleaning with isopropyl alcohol.

CAUTION: Cleaning the Reflector with a rough or dirty cloth will result in a dulled surface, thereby, reducing reflectance and decreasing UV output. Use only a soft, clean cloth.

Any uncured resins spilled onto the Flood Lamp can be removed with isopropyl alcohol and a clean cloth.

TROUBLESHOOTING

NOTE: Only qualified maintenance personnel should attempt the following procedures.

Problem	Possible Cause	Testing	Corrective Action
Lamp Will Not Ignite or Lamp Flickers, Won't Maintain Operation	Improperly fastened connections	Visually inspect all connections to and from the Power Supply.	Secure all connections.
	Main Line Fuses blown	Remove Fuses from Power Receptacle and check with an Ohmmeter.	Replace Fuses, if defective.
	Corroded Lamp Bases	Visually inspect the Lamp Bases for any signs of corrosion.	Replace the Lamp Bases if corrosion exists (both Lamp Bases should be replaced at the same time).
	Bulb beyond its useful life	Replace the Bulb with a Bulb that is good and re-test unit.	Replace the Bulb if defective (typical Bulb life = 2,000 hours).
	Power Supply Board failed	Check the output voltage on the Power Supply Board. Set the Oscilloscope to: 20 ms/div 100 V/div	Expected value 290-340 V/rms Square Wave. Replace the Power Supply Board if defective.
	Ignitor malfunctioned	Verify open circuit voltage from Ignitor. Set the Oscilloscope to: 50 us/div 1000 V/div	Expected value 4-5 KV ignition pulse superimposed on the square wave. Replace if defective.
Unit Blows Input Fuse	Malfunction in the Power Supply Board	Remove power. Disconnect the Lamp/Reflector Assembly from the Power Supply. Replace the Fuse. Apply power. If a Fuse blows, the Power Supply is defective.	Replace the Power Supply Board.
UV Intensity Appears To Be Low	Bulb beyond its useful life	Use a Radiometer (ACCU-CAL™ 50) to measure actual output intensity. Consult manual for proper output.	Replace the Bulb if beyond the useful life (typical life = 2,000 hours).
	Quartz Envelope on Bulb contaminated	Visually inspect the Bulb for signs of contamination (Quartz Envelope must be free from any contamination).	Clean the Bulb with a soft, lint-free cloth and isopropyl alcohol. Bulb may have to be replaced if contamination is burned into Quartz Envelope.
	Surfaces of Reflector may be contaminated	Examine reflector surface for contaminants (should be a clean, shiny surface).	Clean the Reflector with a soft, lint-free cloth and isopropyl alcohol or an equivalent.
	Optional Glass UV Filter contaminated (2000-EC only)	Examine the Glass UV Filter for signs of contamination.	Clean the Glass UV Filter with a soft, lint-free cloth and isopropyl alcohol or an equivalent.

NOTE: When contacting DYMAX, an authorized DYMAX distributor, or manufacturer's representative, be sure to know and provide the following:

- Model number of equipment in question.
- Serial number of equipment in question.
- Product number of the adhesive in question (if applicable).
- Lot number of the adhesive in question (if applicable).

All returns to DYMAX must be accompanied by a return authorization number (ran). This number must be obtained from a DYMAX Customer Service Representative.

SPARE PARTS & ACCESSORIES

ITEM	PART#
Lamp, Metal Halide 400 Watt UV (Standard)*	38560
Lamp, Mercury Vapor 400 Watt UV (Optional)	36970
Lamp, Visible 400 Watt (Optional)	36658
Fuse, F 6.25 Amp*	35141
Optional Fan Assembly (2000-EC, 1200 EC)	38300
Optional Glass UV Filter (2000-EC only)	35899
Lamp Base Replacement Kits*	35979
Goggles, UV safety (Gray)	35285
Goggles, UV safety (Clear)	35612
Power Switch	36288
Mounting Stand Kit, 5000-EC	38289
Mounting Stand Kit, 1200-EC & 2000-EC	38290

* Recommended spare parts

OPTIONS

Several optional accessories are available to enhance efficiency and operation of DYMAX EC-Series UV Light-Curing Flood Lamps. Contact your authorized DYMAX distributor, manufacturing representative, or DYMAX for more information on these options.



Figure 15. ACCU-CAL™ 50 (PN 39561)

UV RADIOMETER (PN 39561)

DYMAX offers an ACCU-CAL™ 50 for monitoring the UV intensity of the EC-Series Flood Lamps. This Radiometer is calibrated to measure UVA output (320-390 nm) wavelength.

Features include:

- Auto ranging, digital readout (1.0 to 40,000 mW/cm²)
- Measures light intensity in mW/cm²
- Powered by AA batteries (included)
- Stores in molded plastic case (included)



Figure 16. Top Ventilation Kit (PN 38300)
Installed on a 1200-EC Lamp

TOP VENTILATION KIT FOR 1200-EC AND 2000-EC LAMPS (PN 38300)

The standard DYMAX EC-Series Lamps employ convection cooling. In situations where supplemental cooling is required or removal of curing vapors from under the Lamp/Reflector Assembly Housing is desired, an optional Ventilation Kit is available. The kit can either be a fixed metal skirt that fits on the rear or on the top of the Lamp/Reflector Assembly Housing. The top fan skirt for the 2000-EC and 1200-EC Lamps is provided with the purchase of a Shutter.

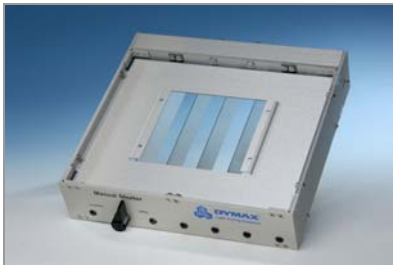

Figure 17. Manual Shutter (PN 35572)

MANUAL LOUVERED SHUTTER (PN 35572) & ELECTRIC ZIP™ SHUTTER (PN 37863)

Safety Enhancing Timing Devices

The DYMAX ZIP™ Shutter (retractable) and Manual Louvered Shutter allow timed light exposure, reduce heat on work area surfaces, and reduce operator exposure to UV light.

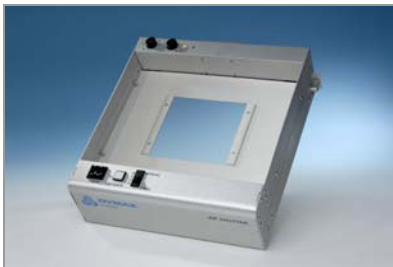

Figure 18. ZIP™ Shutter (PN 37863)



Figure 19. Light Shield (PN 38125)

LIGHT SHIELD (PN 38125)

The Light Shield is a complete enclosure with 360° of shielding. The Light Shield is constructed of UV-opaque acrylic that filters out ultraviolet radiant energy and allows visible light to pass through so that objects can be observed during the curing process.

DEFINITION OF TERMS

Flood Lamp System - Set of components arranged to generate, collect, condition and direct UV radiant energy to perform curing of engineering adhesives, coatings, and inks within a safe and controlled process. It includes a Lamp Housing and Power Supply and may also include a Shutter, Workstation, UV Enclosure, DYMAX Lightshield, and/or accessories.

Lamp - Light source (bulb or burner) generating ultraviolet, visible, and infrared radiant energy from burning matter stimulated by electrical power conditioned by a proper power supply which is an integral part of a Lamp. A light source is usually placed into a reflector (of various geometry) to increase light source efficiency by collecting and directing radiant energy of selected spectra (for a given curing process).

Intensity - a measure of light energy over the unit of surface area (usually surface at the specified working distance from the bottom of a reflector housing) in W/cm^2 or mW/cm^2 . For the UV portion of light, this measure is often called in literature "irradiance", i.e. radiant energy arriving at a point on a surface per unit area.

Brightness, also known as Luminance - description of energy in the visible region of the spectrum (approximately from 400 to 700 nm) and recorded in photometric units. "Intensity" (see below) of visible light energy is called luminance.

Luminance - luminous flux (energy of visible light) incident per unit area, and measured in Lx (lux) or Lumen/cm².

Ultraviolet (UV) - The invisible region of the spectrum just beyond the violet end of the visible region. Wavelength ranges in general from 1.0 to 400 nm. DYMAX Bulbs (burners) do not radiate energy in deep ultraviolet; there are very minute amounts below 220 nm and practically nothing can be sensed below 200 nm. This is due to the use of ozone-blocking Quartz Bulb Envelope (See Ozone).

Ultraviolet is used beneficially in various fields of industry and medicine. In order to standardize light sources used in medicine, the International Congress on Light, in Copenhagen in 1932, recommended dividing the ultraviolet spectrum into three spectral parts:

1. **Ultraviolet A (UV-A)** - UV of long wavelength from within approximately 400 to 320 nm of the spectral band (4000 to 3200 \oplus) - predominately produced by DYMAX Flood Lamps.
2. **Ultraviolet B (UV-B)** - UV of medium wavelength from within approximately 320 to 280 nm - DYMAX Flood Lamps produce some amount of their energy within this bandwidth.
3. **Ultraviolet C (UV-C)** - UV of short wavelength below 280 nm (we say from 280 to 200 nm) – a large amount of this energy is present in the sunlight.

Dose - irradiance integrated over time, or Irradiance (W/cm^2) x Time (s) = Dose (Joules/cm²).

NOTE: Watt is the power that gives rise to the production of energy at the rate of 1-joule (J) per second (s).

Ozone - oxidizing agent (O₃) produced by the action of ultraviolet radiant energy (below 185 nm) or electrical corona discharge of oxygen on air.

OSHA 1910.145: "Regulation of Accident prevention Signs and Tags" defines the following headers as:

WARNING – is used when there is a hazardous situation that has some probability of severe injury.

CAUTION - is used to indicate a hazardous situation that may result in minor or moderate injury.

NOTICE - is used to convey a message related directly or indirectly to the safety of personnel, or protection of property.

WARRANTY

CAUTION!

DYMAX CORPORATION RESERVES THE RIGHT TO INVALIDATE ANY WARRANTIES, EXPRESSED OR IMPLIED, DUE TO ANY REPAIRS PERFORMED OR ATTEMPTED ON DYMAX EQUIPMENT WITHOUT WRITTEN AUTHORIZATION FROM DYMAX. THOSE CORRECTIVE ACTIONS LISTED BELOW ARE LIMITED TO THIS AUTHORIZATION.

DYMAX offers a one-year warranty against defects in material and workmanship on all system components *with proof of purchase date*. Unauthorized repair, modification, or improper use of equipment may void warranty. The use of aftermarket replacement parts not supplied or approved by DYMAX Corporation, will void any effective warranties and may result in damage to the equipment.

© 2006-2011 DYMAX Corporation. All rights reserved. All trademarks in this guide, except where noted, are the property of, or used under license by DYMAX Corporation, U.S.A.

Please note that most dispensing and curing system applications are unique. DYMAX does not warrant the fitness of the product for the intended application. Any warranty applicable to the product, its application and use is strictly limited to that contained in DYMAX's standard Conditions of Sale. DYMAX recommends that any intended application be evaluated and tested by the user to insure that desired performance criteria are satisfied. DYMAX is willing to assist users in their performance testing and evaluation by offering equipment trial rental and leasing programs to assist in such testing and evaluation. Data sheets are available for valve controllers or pressure pots upon request. MAN007 PN 35903 5/13/2011

DYMAX Corporation
860.482.1010
info@dymax.com
www.dymax.com

DYMAX Europe GmbH
+49 (0) 611.962.7900
info_de@dymax.com
www.dymax.de

DYMAX UV Adhesives &
Equipment (Shenzhen) Co Ltd
+86.755.83485759
dymaxasia@dymax.com
www.dymax.com.cn

DYMAX Asia (Hong Kong) Ltd
+852.2460.7038
dymaxasia@dymax.com
www.dymax.com.cn

DYMAX Korea LLC
82.2.784.3434
info@dymax.kr
www.dymax.co.kr

