

12" Wide UV Light-Curing Conveyor

with Multiple Lamp and Part Clearance Options

The DYMAX UVCS series conveyors are designed for curing UV light-curable adhesives, resins, inks, and coatings. These 12" wide conveyors can be outfitted with up to four DYMAX 5000-EC lamps or up to two, six-inch microwave lamps. They offer complete shielding from UV light and consistent cure times. The lamp options allow matching intensity requirements to keep operating costs to a minimum. Standard height clearance is 4 inches; optional risers increase clearance to either 6 or 10 inches.

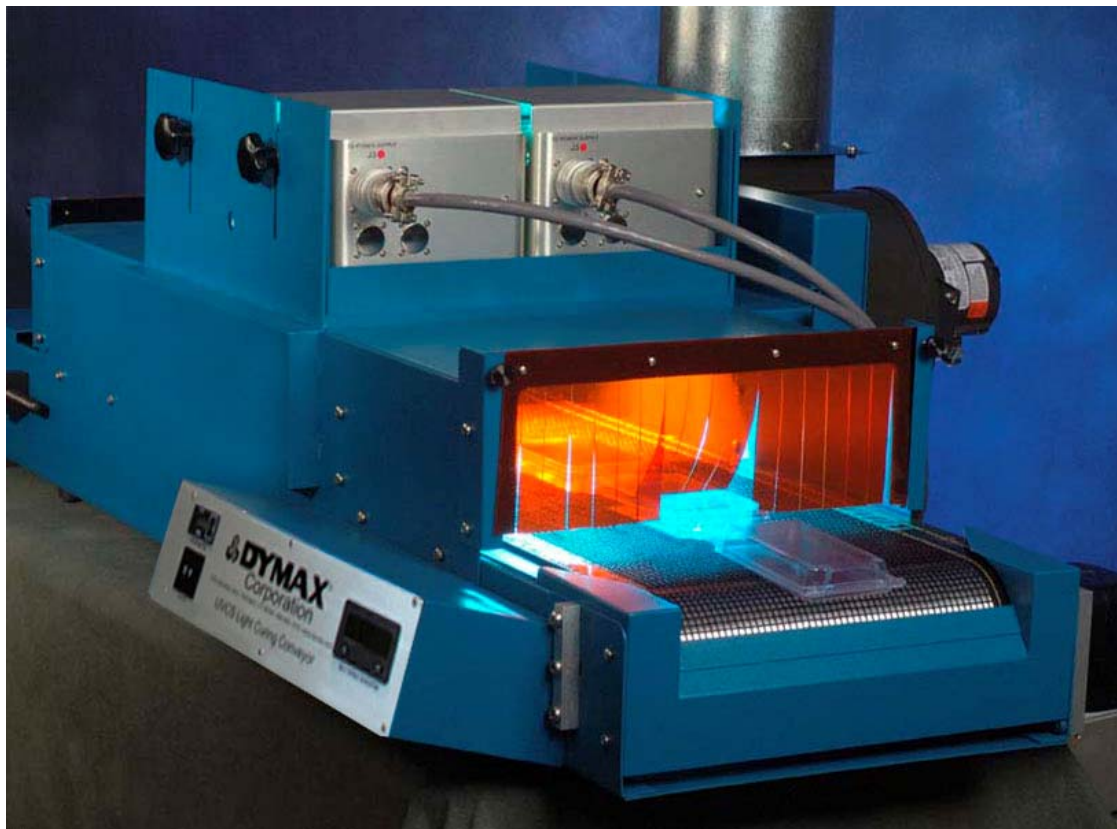

FEATURES	
Complete UV shielding	Built-in exhaust fan and stack
Controlled and consistent cure times	Integral vacuum hold-down and cooling system
Accepts parts up to 12" x 36"	Accurate digital belt control and readout
4", 6", or 10" vertical clearance available	Adjustable lamp-to-belt distance
12" belt width (guides available to channel parts into center 6")	Benchtop conveyor (with optional transportation carrying cart)

Choosing the Right Lamp(s)

UVCS series conveyors can be outfitted with either 5000-EC lamps or Fusion F300 lamps.

5000-EC LAMPS

These lamps provide moderate intensity ($\sim 200 \text{ mW/cm}^2$) over a 6" x 6" (approximate) curing area. Their 400-Watt auto-switching power supplies accept 90 to 264 Volts AC and 47 to 63 Hz. With normal use, 5000-EC bulbs will retain approximately 90% of their original intensity after 1,000 hours. 5000-EC lamps are recommended for small-to-medium throughput bonding applications. For faster or more tack-free cures, Fusion F300 lamps are recommended.

UVCS series conveyors can be outfitted with one, two, or four 5000-EC lamps as shown in the diagrams below.

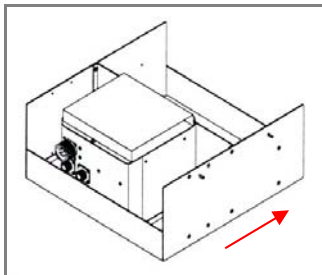

One 5000-EC lamp
center-mounted
6" wide single exposure

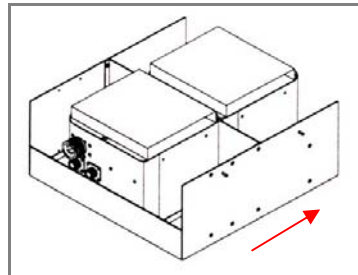

Two 5000-EC lamps
center-mounted
6" wide double exposure

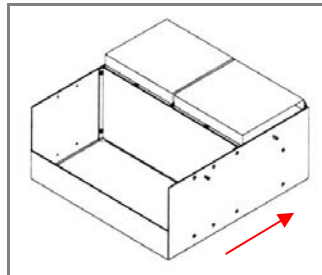

Two 5000-EC lamps
full-width mounted
12" wide single exposure

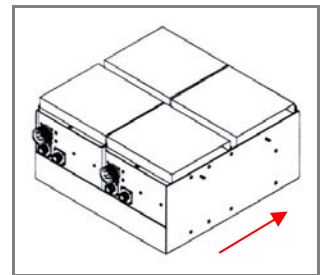

Four 5000-EC lamps
full-width mounted
12" wide double exposure

FUSION F300 LAMPS

These lamps provide the highest intensity ($\sim 2,500 \text{ mW/cm}^2$) over a 1" x 6" curing area. Fusion F300 lamps require 220/230 Volts AC. With normal use, Fusion F300 lamps retain 80% of their intensity up to 5000 hours. Fusion F300 lamps are recommended for most coating, potting, and gasketing applications and all high throughput applications.

UVCS series conveyors can be outfitted with one or two Fusion F300 lamps as shown in the diagrams below.

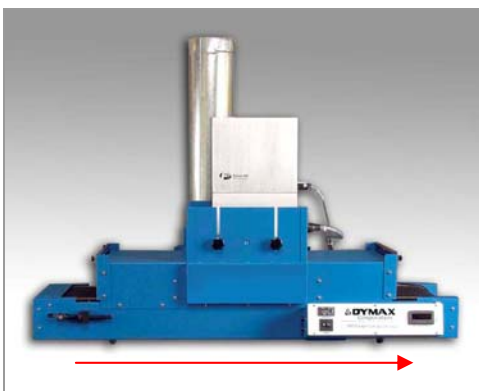

UVCS conveyor with one center-mounted Fusion

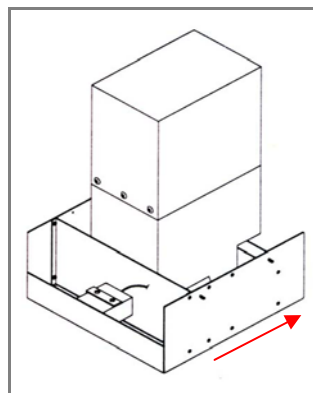

One center-mounted Fusion F300
6" wide single exposure

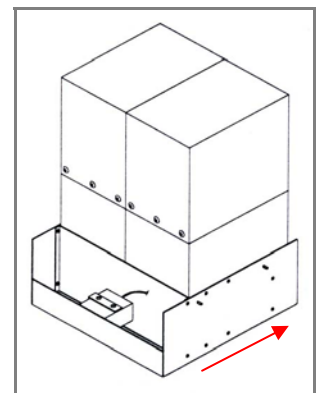

Two full-width mounted
Fusion F300s
12" wide single exposure

5000-EC and F300 Lamp Specifications and Features

	5000-EC LAMPS								FUSION F300 LAMPS	
	UVCS-D5-1-120	UVCS-D5-1-230	UVCS-D5-2A-120	UVCS-D5-2A-230	UVCS-D5-2B-120	UVCS-D5-2B-230	UVCS-D5-4-120	UVCS-D5-4-230	UVCS-F-1-230	UVCS-F-2-230
Part Number	39060	39065	39070	39075	39080	39085	39100	39105	39150	39160
Belt Width	12"								12"	
Lamps 5000-EC Fusion F300	1*		2*		2		4		1*	2
Lamp Orientation CM = center mounted FW = full width	CM				FW				CM	FW
Width of Illuminated Area	6"				12"				6"	12"
Maximum UVA Intensity (320-390 nm)	200 mW/cm ²								2,500 mW/cm ²	
Maximum UVA Energy (320-390 nm) @ 5 fpm (J/cm ²)	1.25		2.50		1.25		2.50		2	
Shipping Weight with Crates (lbs. [kg])	390 [177]		410 [186]				450 [204]		475 [216]	580 [263]
Belt Speeds (feet per minute)	1-32 fpm								1-32 fpm	
Voltage (VAC)	120V	220/230V	120V	220/230V	120V	220/230V	120V	220/230V	220/230V	
Amperage	9.6	4.8	17.6	8.8	17.6	8.8	33.6	16.8	16	32.6
Replacement Bulbs Metal Halide (Standard) #38560 Mercury #36970** "D" Bulb (Standard) #36399 "H" Bulb #36441**	X X	X X	X X	X X	X X	X X	X X	X X	X X	X X

*These conveyors have center-mounted lamps and are supplied with removable guides to channel parts into middle 6" of conveyor.

**These bulbs are primarily designed for curing UV inks and cationic epoxies.

Overall Dimensions For All UVCS Conveyors

- **51"** 129.54 cm long
- **39.5"** 100.33 cm high
- **35"** 88.9 cm wide (from control panel to rear of blower)

UVCS conveyors are available without lamps for those customers that have previously purchased 5000-EC or Fusion F300 lamps. Additional lamps may be incorporated into UVCS conveyors after initial purchase (from one or two Fusion lamps, or up to four 5000-ECs). Contact DYMAX Applications Engineering for configuration assistance.

Accessories and Replacement Parts

ACCESSORIES

ACCU-CAL™ 150 Radiometer	1	40550
Risers Kit 2"	Pair	39218
Risers Kit 6"	Pair	39280
Transportation Cart	1	39215
Guides for 6" Curing	1	39277

REPLACEMENT PARTS

Acrylic Tunnel Shield	1	39205
Tunnel Light Curtain	1	39207
Replacement Belt	1	39134
Extension Shield	1	39209
5000-EC (for conveyors)	1	39241



Transportation Cart



Tunnel Light Curtain

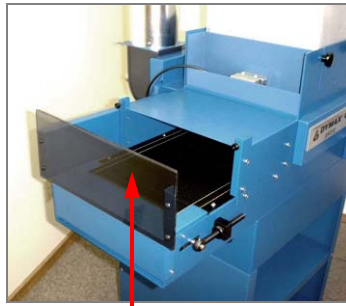

Extension Shield

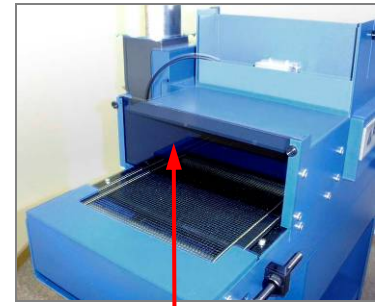

Acrylic Tunnel Shield

© 2006-2011 DYMAX Corporation. All rights reserved. All trademarks in this guide, except where noted, are the property of, or used under license by DYMAX Corporation, U.S.A.

The data contained in this bulletin is of a general nature and is based on laboratory test conditions. DYMAX does not warrant the data contained in this bulletin. Any warranty applicable to the product, its application and use is strictly limited to that contained in DYMAX's standard Conditions of Sale. DYMAX does not assume responsibility for test or performance results obtained by users. It is the user's responsibility to determine the suitability for the product application and purposes and the suitability for use in the user's intended manufacturing apparatus and methods. The user should adopt such precautions and use guidelines as may be reasonably advisable or necessary for the protection of property and persons. Nothing in this bulletin shall act as a representation that the product use or application will not infringe a patent owned by someone other than DYMAX or act as a grant of license under any DYMAX Corporation Patent. DYMAX recommends that each user adequately test its proposed use and application before actual repetitive use, using the data contained in this bulletin as a general guide.

LIT051A 01/28/2011

DYMAX Corporation
860.482.1010
info@dymax.com
www.dymax.com

DYMAX Europe GmbH
+49 (0) 611.962.7900
info_de@dymax.com
www.dymax.de

DYMAX UV Adhesives &
Equipment (Shenzhen) Co Ltd
+86.755.83485759
dymaxasia@dymax.com
www.dymax.com.cn

DYMAX Asia (Hong Kong) Ltd
+852.2460.7038
dymaxasia@dymax.com
www.dymax.com.cn

DYMAX Korea LLC
82.2.784.3434
info@dymax.kr
www.dymax.co.kr

