

# Silver PC Series

## UV Flood Lamp Systems



PC-5000 Models (PN 38004/38005)

PC-2000 Flood Lamps (PN 38002/38003)

PC-1200 Models (PN 38006/38007)

# Operation Manual

---

## TABLE OF CONTENTS

Unpacking and Inspection .....	Page 3
Safety .....	Page 4
General .....	Page 6
Specifications .....	Page 7
Installation and System Connection .....	Page 8
Component Description .....	Page 10
Operation .....	Page 11
Maintenance .....	Page 12
Troubleshooting .....	Page 15
Spare Parts List .....	Page 16
Definition of Terms.....	Page 18
Warranty .....	Page 19

The enclosed DYMAX PC-Series Flood Lamp was developed and manufactured by the DYMAX team, driven by a desire to best serve your needs. Before shipping, your PC-Series Flood Lamp was thoroughly checked and tested for trouble-free performance.

The proper set up and operation of this system will maximize safety and user-friendly performance, providing optimum yield of your technological process.

**THEREFORE, WE ENCOURAGE YOU TO READ, UNDERSTAND, AND FOLLOW ALL SAFETY AND OPERATING INSTRUCTIONS AND RECOMMENDATIONS COMPILED IN THIS AND OTHER RELATED MANUALS** prior to setting up and operating this new flood lamp or its individual components.

If you encounter a problem, have any questions, or would like to help us with your suggestions or recommendations, please contact our Technical or Customer Service Departments at 860-482-1010. Trained DYMAX professionals are standing by to serve you.

## UNPACKING AND INSPECTION

Your DYMAX PC-Series Flood Lamp was shipped to you in a sturdy, reusable box, which is specially designed for safe delivery of the system. Upon receipt of shipment, if carton is visibly damaged, sign for it as damaged or open and request inspection by carrier. If concealed damage is found, notify the carrier and the shipper.

**DYMAX is not responsible for damage from shipping – all claims for shipping damage should be made with the carrier.**

Check all boxes for contents and write down any serial numbers for further reference. If the unit arrived accompanied with other boxes, check the content of all the boxes. You may wish to retain the original shipping cartons in case you need to repackage any item for return.

If you observe or experience any problem with your equipment, notify DYMAX Customer Service, your authorized distributor, or your DYMAX representative immediately.

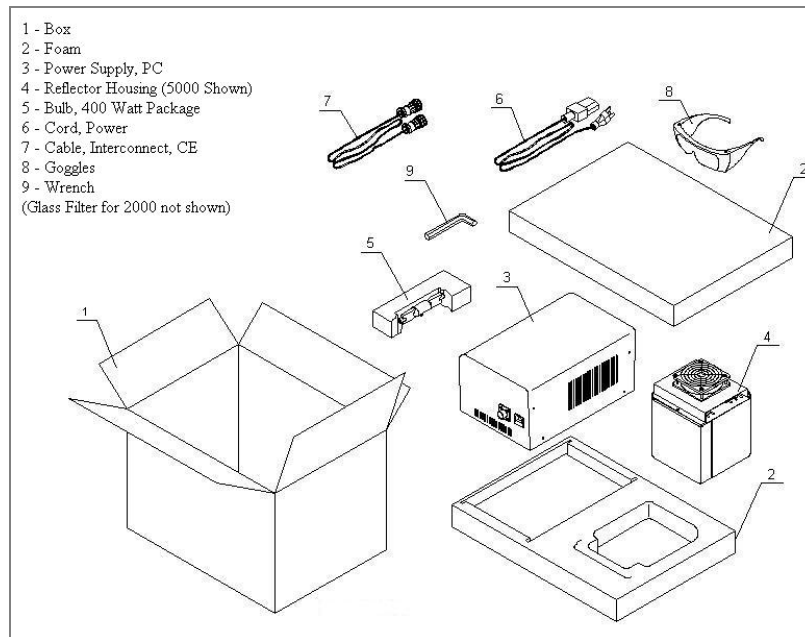

**Figure 1.** PC-5000, PC-2000, & PC-1200 Unpacking Diagram

**NOTE:** Report any shortage to DYMAX Customer Service: Phone: 860-482-1010, Fax: 860-626-7681.

---

Before continuing with unpacking and installation, please read the following chapters of this manual for safety recommendations and installation, operation, and troubleshooting instructions.

## SAFETY

DYMAX equipment is designed to be used properly set up, with components correctly connected, and operated in accordance with these instructions.

**CAUTION!** Always wear protective goggles or face shield when working near UV light!

### SAFETY RECOMMENDATIONS:

- Use the goggles or a face shield approved for UV protection to protect your eyes.
- Long-sleeved shirts or a lab coat are recommended to protect arms and the use of UV opaque gloves will protect the hands.

### Sécurité

L'équipement être conçu pour être utilisé correctement constituer, avec composants brancher correctement, et marché en conformément avec instructions important. Le plan états développer pour rendre au maxime opérateur sécurité et minimiser exposition à ultraviolette.

### RECOMMANDER DE SÉCURITÉ:

- Emploi lunettes, ou un protéger de visage pour protection de ultraviolet pour protéger vous yeux.
- Chemises à manche long, ou manteau de labo, sont recommander pour protéger les bras, et utilisation de ultraviolette gants opaque vais protéger les mains.

**REMARQUER:** avec le filtre intérieur installé, l'Onde Bleu émettre lumière. Ne jamais regardez directement à la source de lumière pendant que l'élément est en opération.

### SICHERHEITSHINWEISE

Dieses Gerät wurde so entwickelt, dass es nur vollständig, alle Komponenten korrekt miteinander verbunden, in Übereinstimmung mit relevanten Instruktionen betrieben wird. Bei der Entwicklung wurde weiterhin großen Wert auf die Benutzersicherheit und minimale UV Belastung gelegt.

### SICHERHEITSHINWEISE:

- Tragen Sie immer die mitgelieferten Sicherheitsbrille oder speziellen Gesichtsschutz, der Ihre Augen vor UV Licht schützt.
- Wir empfehlen Langarm - Hemden oder einen Laborkittel zu tragen, um die Arme zu schützen. Für die Hände empfehlen wir UV- geblockte Handschuhe.

**BITTE BEACHTEN SIE:** Durch den installierten inneren Filter strahlt die UV-Flächenstrahler und sichtbares Licht aus. Schauen Sie deshalb niemals direkt in die Lichtquelle, wenn das Gerät angeschaltet ist.

# DYMAX UV LIGHT-CURING SYSTEM SAFETY CONSIDERATIONS

DYMAX light-curing technology has been used successfully for over 30 years. The fast cure, one-component nature of our curing technology has made it the process of choice for many manufacturers requiring a “Cure on Demand” assembly process. There are four common questions/concerns related to light-curing systems: UV exposure, high-temperature surfaces, ozone, and bright, visible light.

## UV EXPOSURE

Standard DYMAX UV light-curing systems have been designed to primarily emit UVA light (as shown in Chart 1). UVA light is generally considered the safest of the three UV ranges: UVA, UVB, and UVC. Although OSHA does not currently regulate ultraviolet-light exposure in the workplace, the American Conference of Governmental Industrial Hygienists (ACGIH) does recommend Threshold Limit Values (TLV's) for ultraviolet light. The strictest interpretation of the TLV (over the UVA range) for workers' eyes and skin is 1 mW/cm<sup>2</sup> (intensity), continuous exposure. Unless workers are placing bare hands into the curing area, it is unusual to exceed these limits. To put 1 mW/cm<sup>2</sup> limit into perspective, cloudless summer days in Connecticut regularly exceed 3 mW/cm<sup>2</sup> of UVA light and which includes the more dangerous UVB light, primarily responsible for sun tans, sun burns, and skin cancer.

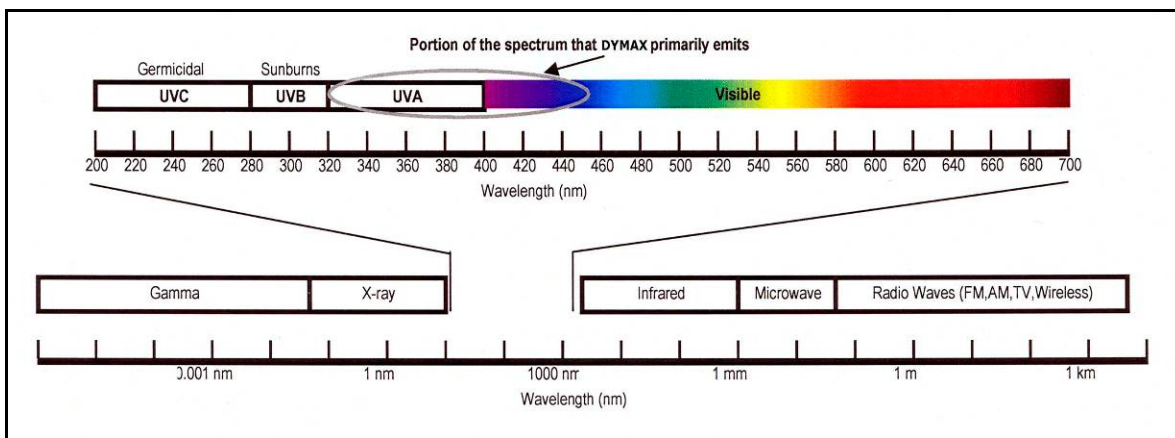

Chart 1. Spectrum of Light

The human eye cannot detect “pure” UV light, only visible light. A radiometer should be used to measure stray UV light to confirm the safety of a UV-curing process. A workstation that exposes an operator to more than 1 mW/cm<sup>2</sup> of UVA continuously should be redesigned.

Light-curing technology can be a regulatory compliant, “worker-friendly” manufacturing process when the proper safety equipment and operator training is utilized. There are two ways to protect operators from UV exposure: shield the operator and/or shield the source.

## SHIELD THE OPERATOR

- **UV-Blocking Eye Protection** – UV-blocking eye protection is recommended when operating UV-curing systems. Both clear and tinted UV-blocking eye protection is available from DYMAX.
- **UV-Blocking Skin Protection** – Where the potential exists for UV exposure upon skin, opaque, UV-blocking clothing, gloves, and full-face shields are recommended.

## SHIELD THE SOURCE OF UV LIGHT

Any substrate that blocks UV light can be used as a shield to protect workers from stray UV light. The following materials can be used to create simple shielding structures:

- **Sheet Metal** – Aluminum, steel, stainless steel, etc. Sheet metal should be coated black or black anodized to minimize reflection of UV and visible light toward operators.

- 
- **Rigid Plastic Film** – Transparent or translucent, UV light-blocking plastics (typically polycarbonate or acrylic) are commonly used to create shielding where some level of transparency is also desired.
  - **Flexible Film** – Translucent UV light-blocking, flexible urethane films can be used to quickly create workstation shielding. This UV light-blocking, flexible urethane film is available from DYMAX.

## HIGH-TEMPERATURE SURFACES

Surfaces exposed to high-intensity curing lights will rise in temperature. The intensity, distance, exposure time, cooling fans, and the type/color of the surface can all affect the actual rise in surface temperature. In some cases, exposed surfaces can reach temperatures capable of producing a burn or causing damage to a substrate. In these cases, care must be taken to ensure either a more moderate surface temperature or appropriate protection/training for operators.

## OZONE

Standard DYMAX bulbs (UVA type) generate an insignificant amount of UVC and therefore essentially no ozone. Some UV light-curing systems, like those used to cure UV inks, emit primarily “shortwave” (UVB and UVC) energy. Upon exposure to UVC energy (specifically <240 nm), oxygen molecules (O<sub>2</sub>) split into oxygen atoms (O) and recombine with O<sub>2</sub> to create ozone O<sub>3</sub>. The current, long-term ozone concentration limit recommended by ACGIH, NIOSH, and OSHA is 0.1 ppm (0.2mg/m<sup>3</sup>).

## BRIGHT, VISIBLE LIGHT

The bright, visible-light energy emitted by light-curing systems can cause eyestrain if proper eye protection or shielding is not used. Tinted eye protection and/or opaque/tinted shielding can be utilized to address this concern.

## SUMMARY

UV light sources can be more “worker friendly” than many commonly accepted industrial processes, provided the potential concerns are addressed. Contact your DYMAX representative for information regarding the proper use of DYMAX UV light-curing systems.

## GENERAL

DYMAX PC-Series Flood Lamps are general purpose units for the curing of UV and visible light-sensitive adhesives, coatings, inks, and any other photosensitive materials. They are used in a wide variety of applications such as bonding, potting, sealing, and encapsulating.

**NOTE:** Users considering special or customized configurations should contact DYMAX Applications Engineering or Customer Service for recommendations and/or guidance to prevent equipment malfunction.

# SPECIFICATIONS

## 2000-PC

Model 2000 Reflector Housing with PC Power Supply (PN 38002 & 38003)	
<b>Voltage</b>	PN 38002 – 115 VAC, 60 Hz PN 38003 – 230 VAC, 50 Hz
<b>Current</b>	4.5 Amp (7-8 Avg. Starting Current)
<b>Fuse</b>	P/N 38002 – 8 Amp 5 x 20 mm P/N 38003 – F6.25 Amp 5 x 20 mm
<b>Starter</b>	Zumtobel ZRM6-ES or Bag Turgi MzN 400 SU
<b>Bulb</b>	400 Watt, metal halide
<b>Reflector</b>	Parabolic, hammertone aluminum
<b>Hour Meter</b>	9,999.9 hours; non-resettable
<b>Cooling</b>	25 CFM, 3.63" square

**NOTE:** A Filter Glass is provided to remove almost all of the measurable UVC and most of the UVB wavelengths. It also reduces IR radiation.

Typical Intensities ** with 115V or 230V (Intensity may vary with power fluctuations)			
Working Area	Wavelength	With Optional Filter Glass Installed	Without Optional Filter Glass Installed
8" x 8" at 0" from the bottom of the Reflector Housing	315-395 nm	70	90

\*\* Measured with a DYMAX ACCU-CAL™ 10 Radiometer, 3" from Glass Filter. Values in mW/cm<sup>2</sup>.

## 5000-PC

Model 5000 Reflector Housing with PC Power Supply (PN 38004 & 38005)	
<b>Voltage</b>	PN 38004 – 115 VAC, 60 Hz PN 38005 – 230 VAC, 50 Hz
<b>Current</b>	4.5 Amp (7-8 Avg. Starting Current)
<b>Fuse</b>	P/N 38004 – 8 Amp 5 x 20 mm P/N 38005 – F6.25 Amp 5 x 20 mm
<b>Starter</b>	Zumtobel ZRM6-ES or Bag Turgi MzN 400 SU
<b>Bulb</b>	400 Watt, metal halide
<b>Reflector</b>	Parabolic, hammertone aluminum
<b>Hour Meter</b>	9,999.9 hours; non-resettable
<b>Cooling</b>	25 CFM, 3.63" square

Typical Intensities ** with 115V or 230V (Intensity may vary with power fluctuations)			
Working Area	Wavelength	3" Below Edge of Housing	5" Below Edge of Housing
5" x 5" at 3" from the bottom of the Reflector Housing	UV-A (365 nm)**	145	100

\*\* Measured with a DYMAX ACCU-CAL™ 10 Radiometer. Values in mW/cm<sup>2</sup>.

## 1200-PC

Model 1200 Reflector Housing with PC Power Supply (PN 38004 & 38005)	
<b>Voltage</b>	PN 38006 – 115 VAC, 60 Hz PN 38007 – 230 VAC, 50 Hz
<b>Current</b>	4.5 Amp (7-8 Avg. Starting Current)
<b>Fuse</b>	P/N 38006 – 8 Amp 5 x 20 mm P/N 38007 – F6.25 Amp 5 x 20 mm
<b>Starter</b>	Zumtobel ZRM6-ES or Bag Turgi MzN 400 SU
<b>Bulb</b>	400 Watt, metal halide
<b>Reflector</b>	Parabolic, hammertone aluminum
<b>Hour Meter</b>	9,999.9 hours; non-resettable
<b>Cooling</b>	25 CFM, 3.63" square

Typical Intensities ** with 115V or 230V (Intensity may vary with power fluctuations)		
Working Area	Wavelength	Intensity
1" x 6" at 3" from the bottom of the Reflector Housing	UV-A (365 nm)	375

\*\* Measured with a DYMAX ACCU-CAL™ 10 Radiometer, 4.5" from the bottom of the reflector. Values in mW/cm<sup>2</sup>.

## INSTALLATION AND SYSTEM CONNECTION

Installation procedure and technique depend on the application of the light source. It may be used as a modular UV-light source (i.e. as an integral part of various technological equipment such as curing chambers, assembly conveyors, rotary assembly installation, etc). Please refer to the appropriate equipment manual for Workstation and Light Shield specific installation instructions.

### INSTALLATION

1. Place the 400 Watt UV Bulb into the Lamp/Reflector Assembly Housing. Refer to the Bulb replacement/ installation section of this manual on page 11.
2. **Optional installation; not required.** The Filter Glass provided reduces the heat produced by the lamp as well as reduces the UV output of the reflector. To install the provided Filter Glass (sold only for the PC-2000):

**NOTICE:** It is important to wear protective gloves when installing the Filter Glass! Do not touch the Filter Glass with bare fingers! Fingerprints may etch into the Filter Glass and cause light transmission loss!

- Place the Reflector Housing (1) up-side down as shown in Figure 2.
- Loosen the screws securing the Reflector Bracket (3).
- Slide the Filter Glass (2) under the brackets and adjust it symmetrically over the reflector aperture.
- Tighten the screws.

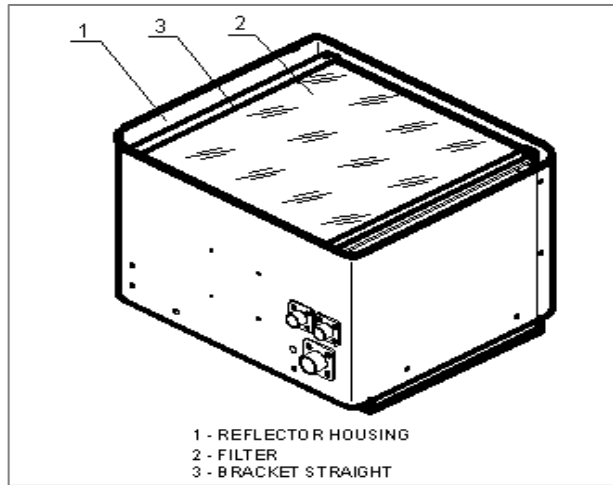

Figure 3. System Interconnect

3. Locate the Power Supply and Reflector Housing so that there is free air circulation around the sides. The Reflector may be mounted to a DYMAX Flood Lamp accessory such as a Workstation, Light Shield, or Shutter. See the connecting instruction in the operation manual for the appropriate DYMAX accessory.

**WARNING!** Always observe safety requirements when working with electrical equipment! Electrical hazard is present!

4. After the bulb is inserted and the Reflector Housing Assembly is placed and secured in the designated operation location, proceed with interconnection as follows:

**NOTE:** Cables and receptacles are coded with color dots to assist in the installation of cables. Connections may vary if using any DYMAX Flood Lamp accessory such as a Workstation, Light Shield, or Shutter. See the connecting instruction in the operation manual for the appropriate DYMAX accessory.

- Connect the Cable (3), as shown in Figure 3, to the J3 Receptacle on the Reflector Housing. Coded red.
- Connect the other end of the Cable (3) to the Lamp Power Receptacle located on the rear panel of the Power Supply (1). Coded red.
- Make sure that DYMAX accessories, if any, are also properly connected and operational.
- Plug the AC Cord into the Power Module located in the rear panel of the Power Supply (1).
- Plug the other end of the AC Cord into appropriate external AC source.

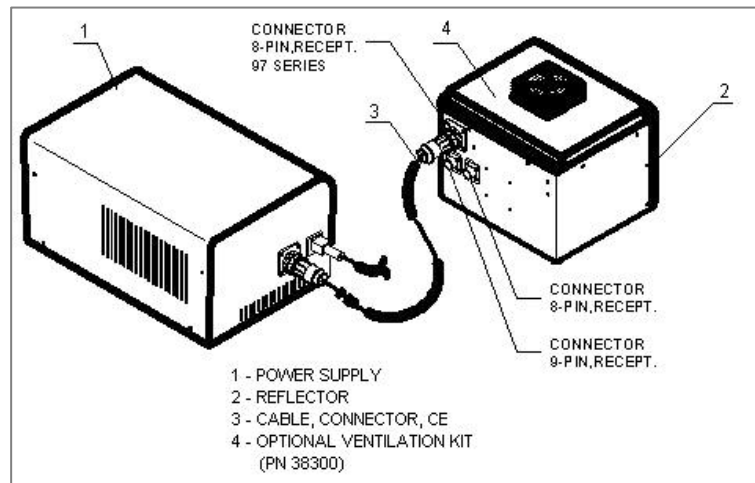

Figure 2. Filter Glass Installation

### IF USING PC-SERIES FLOOD LAMP WITH A WORKSTATION OR LIGHT SHIELD

Follow the instructions in the Workstation or Light Shield manual as applicable.

**NOTE:** When the PC-2000 is used with a Shutter, the Filter Glass is not recommended.

---

## COMPONENT DESCRIPTION

### PC-2000 FLOOD LAMP

The PC-2000 Flood Lamp provides an irradiated area of approximately 8" x 8" making it ideal for batch processing or curing large areas.

The Flood Lamp consists of a Power Supply with Hour Meter, 2000 Flood Light Reflector Housing, Power Cord and Connector Cord for the Reflector Housing, and optional Filter Glass. The Filter Glass alters the UV light and reduces IR (heat) energy distributed over the object. In many cases it improves the curing of heat-sensitive materials. A fan ventilation kit is available as an accessory to remove fumes from under the Lamp during curing of UV light-curable materials. This Flood Lamp can also be used in conjunction with any DYMAX Shutter to allow "on demand" curing.

### PC-5000 FLOOD LAMP

The PC-5000 Flood Lamp provides a 5" x 5" irradiated area of UV light. Because the irradiated area is smaller, it provides light with more than twice the intensity of a DYMAX PC-2000 Flood Lamp. An optional ventilation and cooling fan is provided to cool the housing and ventilate curing vapors away from the Bulb and Reflector.

**The PC-5000 Flood Lamp must be mounted over a fireproof work surface. Sufficient heat energy is generated by the unit to char wood and organic work surfaces.** Initial operation of each installation should be monitored to determine the actual amount of heat generated in work area. The Reflector Housing will become warm and direct skin contact should be avoided when Lamp is in operation. Keep all System Cords out of the irradiated area. The heat will melt the Power Cord insulation. Fixtures and clamps used to hold parts might become very hot. The cure process should be designed to avoid touching hot fixtures.

### PC-1200 FOCUSED-BEAM LAMP

The PC-1200 Focused-Beam Flood Lamp provides an intensely irradiated area of 1" x 6". The Lamp's typical focal point is approximately 4" away from the lower edge of the Reflector Housing.

**The PC-1200 Focused-Beam Lamp must be mounted over a fireproof work surface. Sufficient heat energy is generated by the unit to char wood and organic work surfaces.** Initial operation of each installation should be monitored to determine the actual amount of heat generated in work area. The Reflector Housing will become warm and direct skin contact should be avoided when the Lamp is in operation. Keep all System Cords out of the irradiated area. The heat will melt the Power Cord insulation. Fixtures and clamps used to hold parts might become very hot. The cure process should be designed to avoid touching hot fixtures.

### 400 WATT PC POWER SUPPLY

The Power Supply is a transformer-based power source specifically designed to run 400 Watt metal-halide bulbs. There are two models of this Power Supply: 120 Volts, 60 Hz and 230 Volts, 50 Hz. Models utilize the same enclosure and controls. The front panel of the Power Supply Housing integrates the Bulb's elapsed Time Meter and an illuminated Push-On/Push-Off Switch. An auxiliary 24-Volt DC Power Supply provides power to the Cooling Fans, Control Displays, and auxiliary devices such as Shutters, Meters, and Interlocks.

---

## OPERATION

Press the Power-On Switch on the front panel of the Power Supply. The lighted switch indicates that the Power Supply is on. The Lamp may take up to 30 seconds to ignite. Allow 5 minutes for the Lamp to reach full intensity. The Lamp life is reduced by approximately one hour each time it is started. Each time the Lamp is turned on, it should operate for at least 5 minutes. Failure to do this will result in complete ionization of the elements inside the Lamp. Subsequent attempts to restart the Lamp may fail (see troubleshooting).

**NOTE:** If power is momentarily lost, or the lamp is inadvertently shut off, it must cool for 5-10 minutes before restarting. Power may be left on while the lamp is cooling. It will re-light when it has cooled sufficiently.

**CAUTION:** This lamp generates heat. If the Lamp/Reflector Assembly Housing is located close to the work surface, caution should be exercised. In this situation, a fireproof work surface should be used. Initial operation of each installation should be monitored to determine actual amount of heat generated in the work area. The Lamp/Reflector Assembly Housing will become warm and direct skin contact should be avoided when the Lamp is in operation. Keep the Power Cord and the Connector Cord for the Housing out of the irradiated area.

## MAINTENANCE

The DYMAX PC-Series Flood Lamps are designed to be maintenance free. Periodic cleaning will ensure long, trouble-free usage.

The Cooling Fan, if installed, tends to attract dust and some vapors incurred during adhesive curing. Periodic cleaning of the Lamp and Reflector with a lint-free cloth dampened with isopropyl alcohol will extend the life of the lamp and help to maintain consistent UV output.

### PC-SERIES BULB INSTALLATION/REPLACEMENT

Every new PC-Series Flood System is supplied with a new Bulb. When the Bulb has deteriorated enough to require replacement, the following procedure must be followed:

1. Switch the power off. Disconnect the Power Supply from the electrical outlet.
2. Allow the Lamp to cool.

**CAUTION:** The Lamp operates at temperatures exceeding 500°C. Touching the Lamp before sufficient cool down time is allowed can cause burns. Always wear protective eyewear and gloves while replacing the Bulb.

4. Lift the Housing off the Mounting Stand and place it upside down on a clean work surface.
5. If present, remove the Filter Glass by removing one of the retaining straps held by two 8-32" x 3/8" button head screws with a 3/32" hex wrench. Loosen the two 8-32" x 3/8" button head screws in the remaining strap, so that the Filter Glass can be slid out.
6. Reach into the Lamp/Reflector Assembly and grasp the flat area of the Bulb at either end.

**CAUTION:** Always use a soft, clean, lint-free cloth and gloves when handling the Bulb. Skin oils left on the Lamp will burn into the quartz, reducing output intensity. If the Lamp is inadvertently touched, clean it thoroughly with a soft, clean, lint-free cloth and alcohol.

**NOTE:** An isopropyl alcohol wipe is supplied with the replacement Bulb for cleaning after installation.

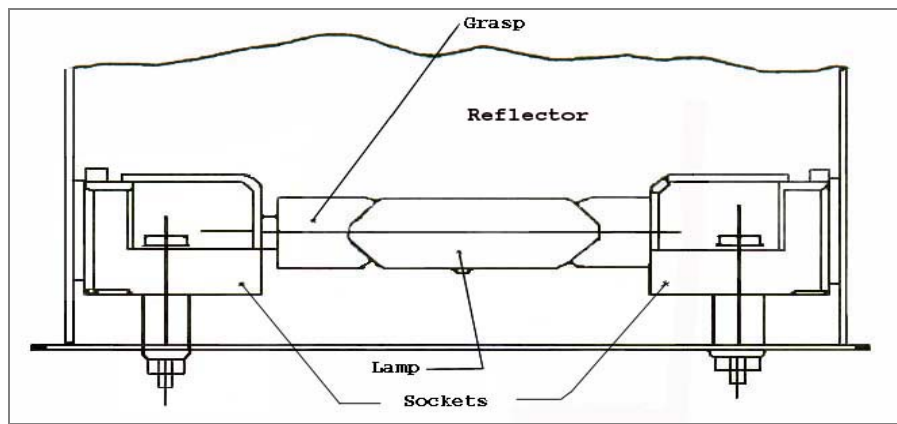

Figure 4. Sectional View of PC-Series Bulb

7. Push the Bulb lightly towards the opposite Socket of the Lamp so that the Bulb end being grasped can be lifted clear of the Socket as shown below in Figures 5 and 6.

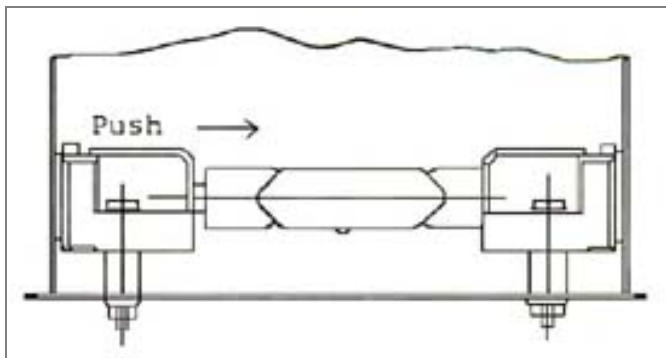

Figure 5.

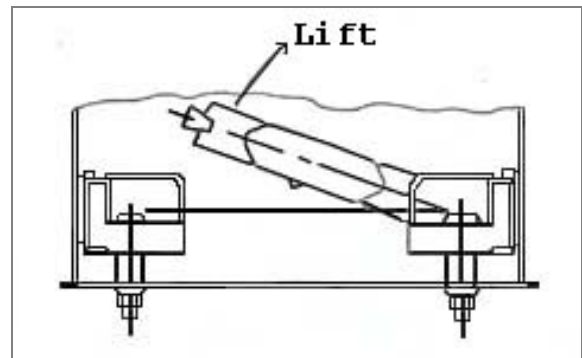

Figure 6.

8. Install the new Bulb by following steps 5, 6, and 7 in reverse order.

**IMPORTANT:** Install the Bulb such that the seal dimple on the bulge of the glass is facing towards the Reflector surface. Avoid touching the quartz tube with your fingers.

**NOTE:** Lamp has no polarity

9. Record the serial number of the unit and the hour-meter reading in the Bulb History Record.
10. Replace the Lamp/Reflector Assembly Housing on the appropriate Mounting Stand.
11. Reconnect the Power Cord to the appropriate Power Source.

The system is now ready for operation.

---

## LAMP BASE REPLACEMENT KIT

1. Turn off the power.
2. Remove the Power Cord and Connector Cord from the unit.
3. Remove the Lamp/Reflector Assembly from the Mounting Stand and place it on a clean, flat surface with the Lamp facing up.
4. Remove the Lamp (refer to Lamp Replacement Procedure).
5. Remove the Lamp/Reflector Assembly from the Housing by removing the four screws, two on each side, from the Reflector.
6. Remove the two screws, from the side of the unit, holding the Ignitor in place (located inside a blue fireproof sleeve) and remove from the sleeve.
7. Loosen the screws and remove the wires from the Ignitor at locations marked N and La.
  - The black Teflon wire at location N will have to be clipped from the lamp base wire and re-stripped.
8. Remove both Lamp Bases and install the new Lamp Bases from the Lamp Base Replacement Kit.
9. Take one of the Lamp Bases and crimp on a supplied Terminal (PN 35202), this wire will be installed in the La location on the Ignitor.
10. The remaining Lamp Base Wire will be joined with the black Teflon wire using the supplied Terminal (PN 35218). This wire will be installed in the N location on the Ignitor.
11. Place the Ignitor back into the blue fireproof sleeve and fasten to the side of the Housing using the two screws that had been removed in Step 6.
12. Place the Reflector back into the Housing and fasten with the four remaining screws.
13. Place the Lamp back into the unit.

## FUSE REPLACEMENT PROCEDURE

The PC-Series 400 Watt Power Supply utilizes two Fuses. One Fuse is external and is located in the Power Cord Receptacle at the rear of the Power Supply Housing. It is an 8 Amp, fast-acting Fuse. The other Fuse is located on the right front-edge of the Power Supply Circuit Board on the inside of the Power Supply Housing. This Fuse is an 8 Amp, slow-blow type.

**WARNING:** Electrical shock hazard. Exercise extreme care when replacing Fuses. Make sure only qualified personnel perform Fuse replacement and that all power switches are off and the power cord is unplugged.

### Replacing External Fuse

1. Turn the Power Supply Power Switch off.
2. Unplug the Power Cord from the electrical source.
3. Unplug the Power Cord from the receptacle at the rear of the Power Supply Housing.
4. Place a small, flat blade screwdriver into the notch at the bottom of the plug recess and pull the Fuse Drawer straight out. DO NOT FORCE: the drawer has a built-in stop to prevent its removal.
5. Slide out the blown Fuse and replace with new 8 Amp, fast-acting Fuse.

**CAUTION:** It is important to replace this Fuse with the same 8 Amp rated, fast-acting type.
6. Slide the Fuse Drawer back into the receptacle until it snaps into place.
7. Replace the Power Cord to the appropriate electrical power source.
8. Turn the Power Switch on.

**NOTE:** Replacement of Internal Fuse should be done by DYMAX Authorized Service Centers only.

---

## **Cleaning**

### **2000-PC**

Periodically remove and clean the Glass Filter. Follow Step 5 in Lamp Replacement Procedure for removal. Clean the Glass Filter with any standard glass cleaner or use isopropyl alcohol for heavy deposits. Reinstall the Glass Filter by following Step 2 of the installation procedure.

**NOTE:** The optional Glass Filter for the 2000-PC loses its ability to transmit UV over time. This is due to “solarization” of the glass caused by the intense UV radiation. Cleaning can extend the useful life of the filter, but its transmission should be monitored periodically and replaced as necessary.

### **2000-PC, 5000-PC, & 1200-PC**

Failure to regularly clean the Glass Filter will result in reduced UV output to the resin being cured, thereby increasing the time required to achieve optimum cure.

Periodically clean the Lamp and Reflector surfaces. A soft, clean cloth and any standard glass cleaner should be used. Heavier deposits may require cleaning with isopropyl alcohol.

**CAUTION:** Cleaning the Reflector with a rough or dirty cloth will result in a dulled surface, thereby, reducing reflectance and decreasing UV output. Use only a soft, clean cloth.

Any uncured resins spilled onto the light source can be removed with isopropyl alcohol and a clean cloth.

## TROUBLESHOOTING

**CAUTION!** Only trained and certified maintenance personnel should attempt repair procedures! For repair assistance please call 860-482-1010

	Possible Cause:	Testing:	Corrective Action:
"Power On" light will not illuminate; no power to unit	No power at receptacle	Check voltage for wall receptacle	Check House Fuses and reset if necessary. Call electrician to check wiring to receptacle.
	Blown Fuse	Test continuity on fuse.	Replace Fuse. A blown Fuse could indicate a more serious problem, so if replaced Fuse is blown, call for service.
"Power On" light illuminates but Bulb will not light	Poor connection at Reflector Housing Cord Plug	Remove power & check to see if Connector is seated correctly.	Reset Connector and try again.
	Poor connection of Bulb to Lamp Bases	Remove power & visually look at Lamp for proper seating.	Reset Bulb and try again.
	Defective Lamp Base(s) or defective or old Bulb	Remove power and look at Lamp Bases' contacts.	If the Lamp Bases appear corroded or discolored, replace with Lamp Base Kit.
	Bulb operated for too short a period on previous use	N/A	<ul style="list-style-type: none"> <li>Remove Bulb &amp; shake; reinstall in reverse direction.</li> <li>Leave power on for several minutes</li> </ul>
	Defective Starter		Call for service
Short Bulb life	Over heating	Bulb Envelope expanded or deformed	Optimum Reflector temperature is between 115°F and 145°F.
	Over cooling	Bulb Blackens	
Light intensity is too low	Dirty Reflector	Visually inspect clarity of Reflector.	Clean or Replace Reflector Assembly.
	Bulb life exceeded	Lamp intensity low with radiometer.	Replace Bulb.
	Low supply voltage	Measure voltage to ensure proper 115 or 230 supply voltage is present.	Provide proper supply voltage to unit.
Adhesive fails to cure or cures slowly	Call DYMAX Technical Service Center or Adhesive Manufacturer.		

**NOTE:** For recommendations, if indicated, about how to replace any specific parts or wiring, please, contact DYMAX Customer Service at 860-482-1010.

## SPARE PARTS

<b>For Models 38002, 38003, 38004, 38005, 38006 &amp; 38007:</b>	<b>Part Number:</b>
400 Watt Bulb	38560
Lamp Base Kit	35979
Starter	35120
Auxiliary 24V Power Supply	37191
Hour Meter	35981
Connector Receptacle PS / Contacts	37865 / 37838
Connector Receptacle Reflector / Contacts	37836 / 37837
Connector Receptacle to Shutter / Contacts	38252 / 38256
Connector Receptacle to Light Shield / Contacts	38253 / 38256
Connector Cable Power Supply / Reflector	37904

<b>For Models 38002, 38004, &amp; 38006:</b>	<b>Part Number:</b>
PC Power Supply (Complete) 120V	38250
Transformer & Capacitor Assembly	38347
Power Switch	35138
8 Amp Fuse 250V	35512

<b>For Models 38003, 38005, &amp; 38007:</b>	<b>Part Number:</b>
PC Power Supply (Complete) 230V	38251
Transformer	37956
Power Switch	37009
6.25 Amp Fuse 250V	38258

<b>For Models 38002 &amp; 38003:</b>	<b>Part Number:</b>
2000 Reflector Complete	38180
Reflector 2000	36189

<b>For Models 38004 &amp; 38005:</b>	<b>Part Number:</b>
5000 Reflector Complete	38179
Reflector 5000	36190

<b>For Models 38006 &amp; 38007:</b>	<b>Part Number:</b>
1200 Reflector Complete	38181
Reflector 1200	36188

---

**OPTIONS/ACCESSORIES:**

<b>Description:</b>	<b>Part Number:</b>
UV Light Shield	38125
UV Light Shield with Manual Shutter	39023
UV Light Shield with Zip Shutter	39021
Mounting Stand Kit 2000	38290
Mounting Stand Kit 5000	38289
Junction Box Retrofit Kit (Silver to Blue)	38123
Junction Box Retrofit Kit (Blue to Silver)	38124
Mounting Stand	38386
Glass Filter for 2000 Reflector	35899
Fireproof Work Surface 2000 & 1200	38389
Fireproof Work Surface 5000	37152
Connector Cable Shutter / Reflector	38239
Connector Cable Light Shield / Reflector	38240
Ventilation Kit 2000	38300
UV Protective Goggles – Grey	35285
UV Protective Goggles – Amber/Brown	38399
UV Protective Goggles – Clear	35185
UV Protective Goggles – Green 5.0	35286
UV Protective Spectacles - Grey	35613
UV Protective Spectacles - Amber	38348
UV Protective Spectacles - Clear	35612
UV Protective Spectacles - Mirrored	35643
UV Protective Spectacles – Green 3.0	35614
UV Protective Spectacles – Green 5.0	38349
UV Protective Face Shield – Clear	35186
UV Protective Face Shield – Green 5.0	38407

---

## DEFINITION OF TERMS

**Bulb** - Light source generating Ultraviolet, Visible, and Infrared radiant energy from burning matter stimulated by electrical power conditioned by a proper power supply which is an integral part of a Lamp. A light source is usually placed into a reflector (of various geometry) to increase light source efficiency by collecting and directing radiant energy of selected spectra (for a given curing process).

**Intensity** - a measure of light energy over the unit of surface area (usually surface at the specified working distance from the bottom of a reflector housing) in  $W/cm^2$  or  $mW/cm^2$ . For the UV portion of light, this measure is often called in literature "irradiance", i.e. radiant energy arriving at a point on a surface per unit area.

**Brightness**, also known as **Luminance** - description of energy in the visible region of the spectrum (approximately from 400 to 700 nm) and recorded in photometric units. "**Intensity**" (see below) of visible light energy is called Illuminance.

**Illuminance** - luminous flux (energy of visible light) incident per unit area, and measured in **Lx** (lux) or **Lumen/cm<sup>2</sup>**.

**Ultraviolet (UV)** - The invisible region of the spectrum just beyond the violet end of the visible region. Wavelength ranges in general from 1.0 to 400 nm. DYMAX bulbs (burners) do not radiate energy in deep Ultraviolet; there are very minute amounts below 220 nm and practically nothing can be sensed below 200 nm. This is due to the use of an ozone blocking quartz bulb envelope (See Ozone).

1. **Ultraviolet A (UV-A)** - UV of long wavelength from within approximately 400 to 320nm of the spectral band (4000 to 3200 $\oplus$ ) - predominately produced by DYMAX Flood Lamps.
2. **Ultraviolet B (UV-B)** - UV of medium wavelength from within approximately 320 to 280nm - DYMAX Flood Lamps produce some amount of their energy within this bandwidth.
3. **Ultraviolet C (UV-C)** - UV of short wavelength below 280nm (we say from 280 to 200nm) – a large amount of this energy is present in the Sunlight.
4. **Visible** – Light that can be seen 400-700 nm.

**Dose** - is irradiance integrated over time, or Irradiance ( $W/cm^2$ ) x Time (s) = Dose (Joules/cm<sup>2</sup>). Note: Watt is the power that gives rise to the production of energy at the rate of 1-joule (J) per second (s).

**Ozone** - oxidizing agent (O<sub>3</sub>) produced by the action of Ultraviolet radiant energy (below 185 nm) or electrical corona discharge of oxygen on air.

**OSHA 1910.145:** "Regulation of Accident prevention Signs and Tags" defines the following headers as:

**WARNING** – is used when there is a hazardous situation that has some probability of severe injury.

**CAUTION** - is used to indicate a hazardous situation that may result in minor or moderate injury.

**NOTICE** - is used to convey a message related directly or indirectly to the safety of personnel, or protection of property.

---

## WARRANTY

### CAUTION!

DYMAX CORPORATION RESERVES THE RIGHT TO INVALIDATE ANY WARRANTIES, EXPRESSED OR IMPLIED, DUE TO ANY REPAIRS PERFORMED OR ATTEMPTED ON DYMAX EQUIPMENT WITHOUT WRITTEN AUTHORIZATION FROM DYMAX. THOSE CORRECTIVE ACTIONS LISTED BELOW ARE LIMITED TO THIS AUTHORIZATION.

DYMAX offers a one-year warranty against defects in material and workmanship on all system components *with proof of purchase date*. Unauthorized repair, modification, or improper use of equipment may void warranty. The use of aftermarket replacement parts not supplied or approved by DYMAX Corporation, will void any effective warranties and may result in damage to the equipment.

**For further assistance with equipment, contact DYMAX Applications Engineering.**



In the U.S. Call: 877.396.2988  
In North and South America Call: +1.860.482.1010  
In Europe Call: +49 (0) 611.962.7900  
In Asia Call: +86.755.83485759  
In Korea Call: 82.2.784.3434

[www.dymax.com](http://www.dymax.com) ♦ [www.dymax.de](http://www.dymax.de) ♦ [www.dymax.com.cn](http://www.dymax.com.cn) ♦ [www.dymax.co.kr](http://www.dymax.co.kr)

**DYMAX Corporation** - 318 Industrial Lane - Torrington, CT 06790 - Phone: 860.482.1010 - Fax: 860.496.0608 - E-mail: [info@dymax.com](mailto:info@dymax.com) - [www.dymax.com](http://www.dymax.com)

**DYMAX Europe GmbH** - Kasteler Strasse 45 – Building G 359 - 65203 Wiesbaden, Germany - Phone: +49 (0) 611.962.7900 - Fax: +49 (0) 611.962.9440 - E-mail: [info\\_de@dymax.com](mailto:info_de@dymax.com) - [www.dymax.de](http://www.dymax.de)

**DYMAX UV Adhesives & Equipment (Shenzhen) Co., Ltd** - Unit 807, Talfook Building, No. 9 Shihua Road, Futian Free Trade Zone, Shenzhen, China 518038 - Phone: +86.755.83485759 - Fax: +86.755.83485760 - E-mail: [dymaxasia@dymax.com](mailto:dymaxasia@dymax.com) - [www.dymax.com.cn](http://www.dymax.com.cn)

**DYMAX Asia (HK)** - Room 1103, 11/F., Metro Centre, Phase I, 32 Lam Hing St., Kowloon Bay, Hong Kong - Phone: +852.2460.7038 - Fax: +852.2460.7017 - E-mail: [dymaxasia@dymax.com](mailto:dymaxasia@dymax.com) - [www.dymax.com.cn](http://www.dymax.com.cn)

**DYMAX Korea LLC** - #903, CCMM B/D, 12 Yeoido-Dong, Youngdungpo-Gu, Seoul, Korea, 150-869 - Phone: 82.2.784.3434 - Fax: 82.2.784.5775 - E-mail: [info@dymax.kr](mailto:info@dymax.kr) - [www.dymax.co.kr](http://www.dymax.co.kr)

© 2003-2010 DYMAX Corporation. All rights reserved. All trademarks in this guide, except where noted, are the property of, or used under license by DYMAX Corporation, U.S.A.

Please note that most dispensing and curing system applications are unique. DYMAX does not warrant the fitness of the product for the intended application. Any warranty applicable to the product, its application and use is strictly limited to that contained in DYMAX's standard Conditions of Sale. DYMAX recommends that any intended application be evaluated and tested by the user to insure that desired performance criteria are satisfied. DYMAX is willing to assist users in their performance testing and evaluation by offering equipment trial rental and leasing programs to assist in such testing and evaluation. Data sheets are available for valve controllers or pressure pots upon request.

MAN006 PN38259 06/17/2010