

# UV Light Shield

For Use with DYMAX Flood Lamp Systems



DYMAX UV Light Shield (PN 38125)

## Operation Manual

---

## TABLE OF CONTENTS

Introduction .....	Page 3
Unpacking and Inspection .....	Page 3
General Information .....	Page 4
Components Description .....	Page 4
Specifications .....	Page 5
Installation System Interconnect.....	Page 6-9
Operation .....	Page 10
Maintenance & Troubleshooting .....	Page 10
Spare Parts List .....	Page 10
Definition of Terms.....	Page 11
Warranty .....	Page 11

# INTRODUCTION

The enclosed DYMAX UV Light Shield for Flood-Lamp Systems and its unique components were developed and manufactured by a DYMAX team driven by a desire to best serve your needs. Before shipping, the Light Shield was thoroughly checked and tested for trouble-free performance.

The proper set up and operation of this Light Shield will assure long, safe, and user-friendly performance, providing optimum yield from your light-curing process.

**THEREFORE, WE ENCOURAGE YOU TO READ, UNDERSTAND, AND FOLLOW ALL SAFETY AND OPERATING INSTRUCTIONS AND RECOMMENDATIONS COMPILED IN THIS AND OTHER RELATED MANUALS** prior to setting up and operating this new Light Shield or its individual components.

If you encounter a problem, have any questions, or would like to help us with your suggestions or recommendations, please contact DYMAX Applications Engineering or Customer Support Departments.

# UNPACKING AND INSPECTION

Upon receipt of the unit, carefully remove the contents from the boxes and check for damage. DYMAX is not responsible for damage from shipping – all claims for shipping damage should be made with the carrier.

Check all boxes for contents and write down any serial numbers for further reference. You may wish to retain original shipping cartons in case you need to repackage any item for return.

If you observe or experience any problem with your equipment, notify DYMAX Customer Service, your authorized DYMAX distributor, or your DYMAX representative immediately.

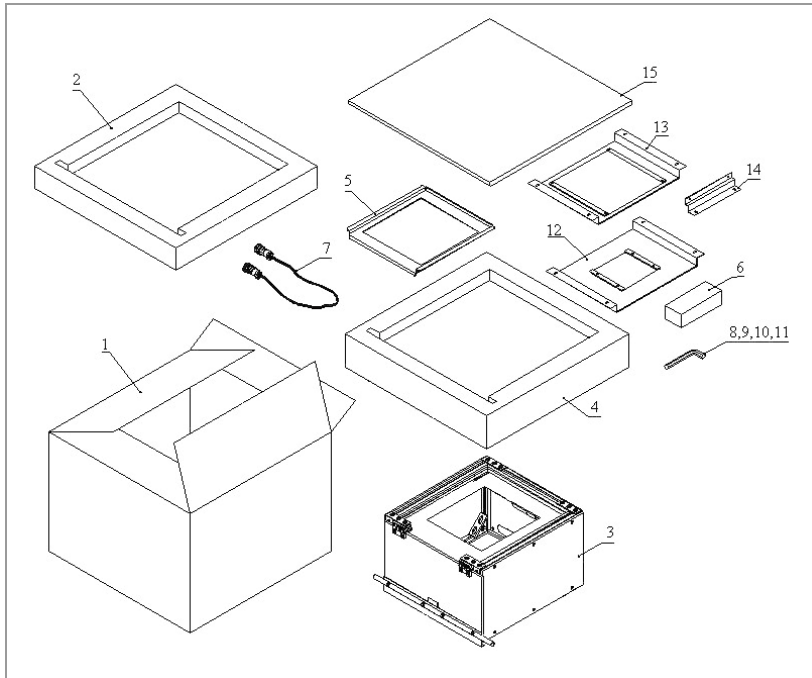

Figure 1. Light Shield Unpacking Diagram

Light Shield (PN 38125) Parts List	
#	Part
1	Shipping Box
2	Foam Bottom
3	Light Shield
4	Foam Accessory
5	Light Shield Tray
6	Goggles
7	Cable
8	1/8" Hex Wrench
9	5/32" Hex Wrench
10	3/32" Hex Wrench
11	5/64" Hex Wrench
12	5000 Reflector Adapter Plate
13	2000 Reflector Adapter Plate
14	Support Bracket
15	Cardboard
16	Screw 8-32 x 3/8" (Not Shown)

**NOTE: REPORT ANY SHORTAGE TO DYMAX CORPORATION CUSTOMER SUPPORT**

---

## GENERAL INFORMATION

The UV Light Shield is part of a Flood Lamp Curing System that incorporates an optional Shutter and a Light Source into a unique system, generating conditioned quality UV light for curing photosensitive adhesives, coatings, and inks applied to various size and shape parts. There is a choice of two types of Shutters designed for the Flood Lamp Curing System and six Flood Lamp models which can be integrated into the Flood Lamp Curing System to optimize your application, providing higher throughput at the best curing quality. The Flood Lamp Curing System can also be used without the Shutter, for example, in rare cases when especially long (several hours) exposure is needed, or timing accuracy is not an issue.

The UV Light Shield can accommodate all DYMAX AS, PC, and EC Silver Series Flood Lamps.

**NOTE:** Users considering special or customized configurations should contact DYMAX Applications Engineering for recommendations and/or guidance to prevent equipment malfunction. DYMAX cannot foresee every possible use of these light sources and reserves the right to invalidate warranties, expressed or implied, due to non-recommended installation or use of this equipment.

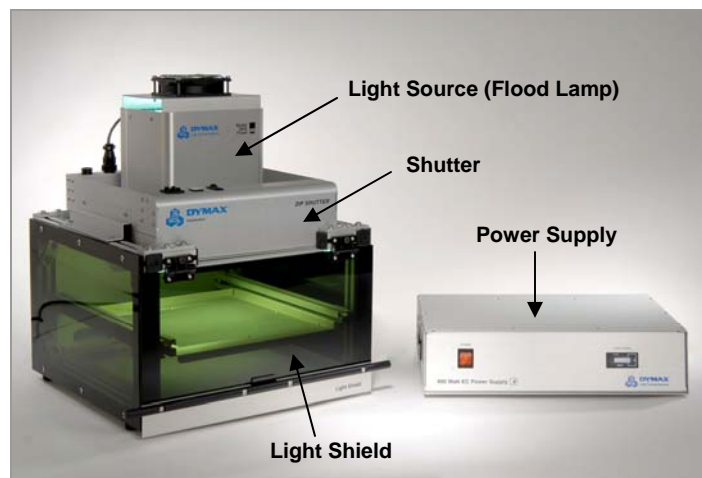

Figure 2. DYMAX Flood Lamp Curing System

## COMPONENTS DESCRIPTION

The Light Shield is the base of the Flood Lamp System (see Figure 2). It is constructed of UV-blocking acrylic material that filters out UV light. At the same time, it allows some visible light to pass through so the operator can safely observe objects in the curing process.

The Light Shield features a front loading door which swings up and down on the dual supporting hinges. The door has an optional Interlock Switch (PN 38402) that can be installed with ZIP™ Shutters to prevent the Shutter from being open when the Light Shield's door is open.

A fireproof tray is included with the Light Shield. The tray slides along the adjustable height rails and can be removed and replaced with ease.

---

## SPECIFICATIONS

<b>Part Number</b>	<b>PN 38125</b>
<b>Compatible DYMAX Flood Lamps</b>	5000-PC / 5000-EC 2000-PC / 2000-EC 1200-PC / 1200-EC
<b>Compatible DYMAX Bulbs</b>	Standard – 400 Watt Metal Halide Bulb Optional – 400 Watt Hg Vapor Bulb Optional – 400 Watt Visible Bulb
<b>Work Area</b>	10" x 10" (25.4 cm x 25.4 cm)
<b>Work Surface Load Capacity</b>	Up to 5 lbs.
<b>Overall Dimensions (W x D x H)</b>	17" x 18" x 10.5" (43.18 cm x 45.72 cm x 26.67 cm)
<b>Weight*</b>	14 lbs. (6.35 kg)

\* Less Shutter, Power Supply, Reflector Housing, and accessories

## FEATURES

- Accommodates parts for curing up to 7.5" high without drawer.
- Work surface may be adjusted from 2" to 6.5" from the bottom of the enclosure.
- Door operation modes: Door interlocked option is available for use with ZIP™ shutters only.

# INSTALLATION AND SYSTEM CONNECTION

Place the Light Shield on the designated workbench. Remove all packaging used for securing the unit during shipping and save it in the event you need to repackage the unit for return.

## SUGGESTED SEQUENCE OF FLOOD LAMP CURING SYSTEM CONNECTION:

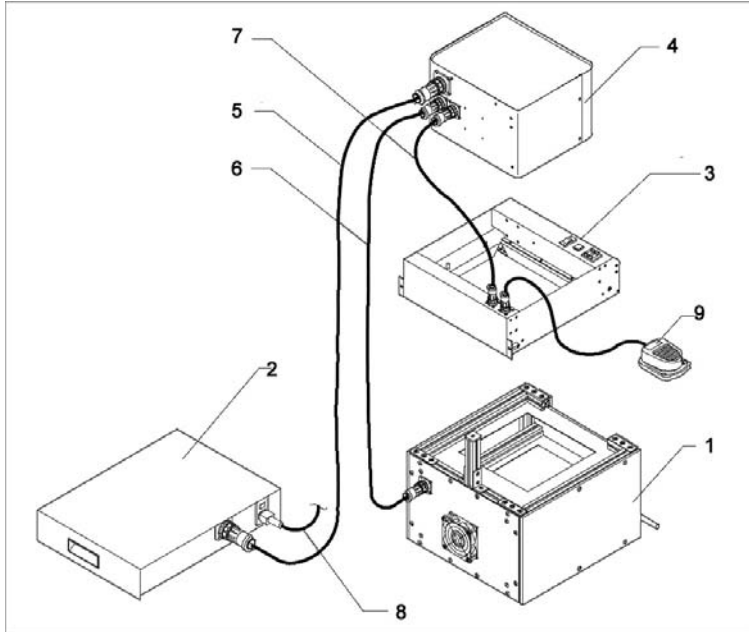

Flood Lamp System Parts List	
#	Part
1	Light Shield Assembly
2	Power Supply
3	ZIP™ Shutter Assembly (optional)
4	Reflector Housing Assembly
5	Connection Cable, Interconnect, CE
6	Cable, Reflector Housing to Light Shield
7	Cable, Reflector Housing to Shutter
8	AC Power Cord
9	Foot Pedal

Figure 3. Flood Lamp Curing System Interconnect

1. Install the Bulb (included) into the Reflector Housing Assembly (4); follow the installation instructions provided with the Bulb.
2. Connect the Connection Cable (5) to the rear panel of the Power Supply (2) and then to the 8-Pin Receptacle in the rear of the Reflector Housing Assembly (4).
3. Connect the Foot Pedal (9) to 4-Pin Receptacle right rear of the Shutter (3)
4. Connect the Cable (7) provided with the Shutter (3) from the 8-Pin Connector on the rear of the Reflector Housing Assembly (4) to the 8-Pin Connector on the rear of the ZIP™ Shutter (3).
5. Connect the Cable (6) provided with the Light Shield (1) from the 9-Pin Connector on the rear of Reflector Housing Assembly (4) to the 9-Pin Connector located on back of Light Shield (1).
6. Plug the female connector of an AC Power Cord (8) into the male receptacle on the rear panel of the Power Supply (2).

---

## INSTALLING LIGHT SHIELD WITH REFLECTOR HOUSING:

1. Prepare the Reflector Housing with the appropriate Support Plate provided with the Light Shield. Place the Reflector on its top. Remove the four screws from corner of the Reflector Housing.
2. Using the four screws that were removed in Step 1, assemble the appropriate Support Plate to the bottom of the Reflector Housing (See Figures 4-6).
3. Place the Reflector Housing/Support Plate Assembly onto the Light Shield (Figure 7-9). Using the 8-32 x  $\frac{3}{8}$ " screws provided with the Shutter, secure the Reflector/Support Plate(s) Assembly to the Light Shield.

**NOTE:** Do not tighten until directed in Step 4.

4. Center the Reflector Housing on the Light Shield. When the desired position is achieved, tighten the Securing Brackets to the Light Shield.



**Figure 4.** 1200-EC Reflector Housing With Support Plate Attached



**Figure 5.** 2000-EC Reflector Housing With Support Plate Attached (Front)



**Figure 6.** 5000-EC Reflector Housing with Support Plate Attached (Front)



**Figure 7.** 1200-EC Reflector Housing Mounted on Light Shield



**Figure 8.** 2000-EC Reflector Housing Mounted on Light Shield



**Figure 9.** 5000-EC Reflector Housing Mounted on Light Shield

---

## INSTALLING LIGHT SHIELD WITH REFLECTOR HOUSING AND SHUTTER:

1. Take a Shutter and carefully place it on the top of the Light Shield.
2. Install the Support Brackets to the top of Light Shield with the 8-32 x  $\frac{3}{8}$ " screws provided.

**NOTE:** Do not tighten until directed to in Step 5.

3. Prepare the Reflector Housing with the appropriate Support Plate(s) for use with the Shutters as described in the Shutter manuals (Figures 10-11).

**NOTE:** Do not install the Reflector Housing to the Shutter by installing the four 8-32 x  $\frac{3}{8}$ " screws and fastening the Support Plate(s) to the Reflector Housing until directed.

4. Place the Reflector Housing/Support Plate(s) Assembly into the Shutter. Using the 8-32 x  $\frac{3}{8}$ " screws provided with the Shutter, secure the Light Shield and Shutter to the Reflector Housing Support Plate(s) Assembly.
5. Center the Shutter on the Light Shield. When the desired position is achieved, tighten the Securing Brackets to the Light Shield.

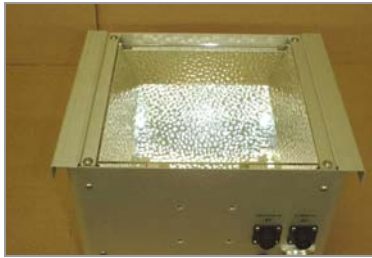

**Figure 10.** 2000-EC Reflector Housing With Support Plate Attached (Front)



**Figure 11.** 5000-EC Reflector Housing with Support Plate Attached (Front)



**Figure 12.** 2000-EC Reflector Housing Mounted on ZIP™ Shutter and Light Shield



**Figure 13.** 5000-EC Reflector Housing Mounted on ZIP™ Shutter and Light Shield

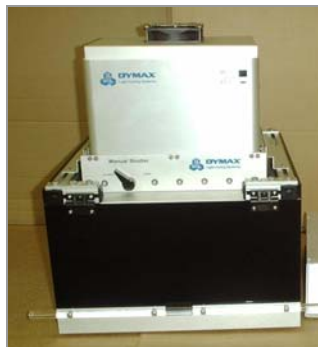

**Figure 14.** 2000-EC Reflector Housing Mounted on Manual Shutter and Light Shield



**Figure 15.** 5000-EC Reflector Housing Mounted on Manual Shutter and Light Shield

## OPTIONAL: ASSEMBLING THE SAFETY INTERLOCK SWITCH

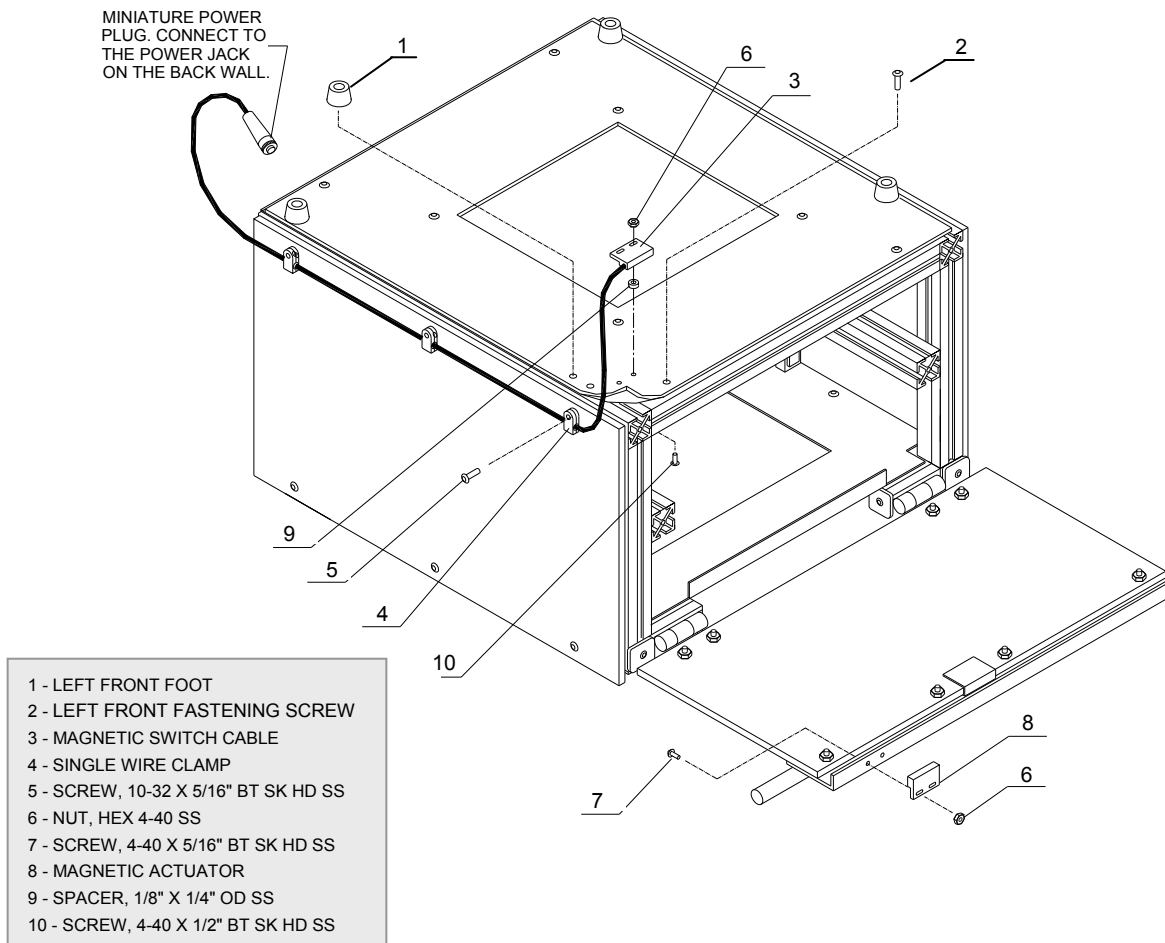

Figure 16. Light Shield in Upside Down Position

1. Remove the Reflector Housing and Shutter from the top of the Light Shield. Turn the Light Shield upside-down as shown in Figure 16.
2. Remove the Left Front Foot (1) and the Left Front Fastening Screw (2) with a hex wrench. Lift the corner of the Light Shield's Bottom Plate to allow access under it.
3. Attach the Magnetic Switch Cable (3) to the Light Shield's Bottom Plate using the two 4-40 Screws with nuts (6 & 10) and spacers (9).
4. Reinstall the Left Front Fastening Screw (2) and Left Front Foot (1) to the bottom of the Light Shield.
5. Remove the three 10-32 screws (5) from the left side of the Light Shield. Route the Interlock Switch Cable along the left side of the Light Shield and fasten the cable into place by using the three Cable Clamps (4) and longer screws provided in this kit.
6. Attach the Magnetic Actuator (8) to the Light Shield's front door using the 4-40 Hex Nuts (6) and screws provided as shown in Figure 16.
7. Plug the Connector to the Power Jack at the back of the Light Shield.
8. Turn the Light Shield right side up and reinstall the Shutter and Reflector to the Light Shield.

---

## OPERATION

For a detailed description of Flood Lamp operation, maintenance, and troubleshooting see the appropriate Flood Lamp operation manual. This is a suggested sequence of activities that can be altered to better match your working conditions, process requirements, and work habits.

Estimate the height of the curing part in respect to its base, or to the base of the part holder (if the object to be cured is not free standing), and then adjust the position of the work surface at a proper distance from the curing part. Use a ruler for setting accuracy.

The recommended working distances for each type of Reflector Housing Assembly is indicated in the appropriate Flood Lamp manual. You can set this distance differently to optimize your throughput with respect to adhesive properties and irradiant energy required to achieve the best curing quality in the shortest time. DYMAX Applications Engineering is ready to assist you if needed.

## MAINTENANCE & TROUBLESHOOTING

For detailed technical assistance, please call the DYMAX Applications Engineering.

### UV SHIELD

The UV Light Shield is designed to be maintenance free. Periodic cleaning will ensure long trouble-free operation.

### FLOOD LAMPS

See the appropriate Flood Lamp manual for maintenance recommendations.

### SHUTTERS

See the appropriate Shutter manual for maintenance recommendations.

## SPARE PARTS LIST

Item	Part #
UV Shield, side, two panels (for complete wall, requires two)	38291
UV Shield door, two panels (for complete wall, requires two)	38292
Fan (24 Volts)	35761
Interlock Switch	38402
Worksurface Tray Assembly	38330
Cable, Reflector Housing to Light Shield	38239
Hinge, Friction, Adjustable	36447
Front Door Handle, Plastic	38204

---

## DEFINITION OF TERMS

**Bulb** - light source generating ultraviolet, visible, and infrared radiant energy from burning matter stimulated by electrical power conditioned by a proper power supply which is an integral part of a lamp. A light source is usually placed into a reflector (of various geometry) to increase light source efficiency by collecting and directing radiant energy of selected spectra (for a given curing process).

**Intensity** - a measure of light energy over the unit of surface area (usually surface at the specified working distance from the bottom of a reflector housing) in  $W/cm^2$  or  $mW/cm^2$ . For the UV portion of light, this measure is often called in literature "irradiance", i.e. radiant energy arriving at a point on a surface per unit area.

**Brightness**, also known as **Luminance** - description of energy in the visible region of the spectrum (approximately from 400 to 700 nm) and recorded in photometric units. "**Intensity**" (see below) of visible light energy is called Luminance.

**Luminance** - luminous flux (energy of visible light) incident per unit area, and measured in **Lx** (lux) or **Lumen/cm<sup>2</sup>**.

**Ultraviolet (UV)** - The invisible region of the spectrum just beyond the violet end of the visible region. Wavelength ranges in general from 1.0 to 400 nm. DYMAX bulbs (burners) do not radiate energy in deep Ultraviolet; there are very minute amounts below 220 nm and practically nothing can be sensed below 200 nm. This is due to the use of an ozone blocking quartz bulb envelope (See Ozone).

1. **Ultraviolet A (UV-A)** - UV of long wavelength from within approximately 400 to 320 nm of the spectral band (4000 to 3200Å) - predominately produced by DYMAX Flood Lamps.
2. **Ultraviolet B (UV-B)** - UV of medium wavelength from within approximately 320 to 280 nm - DYMAX Flood Lamps produce some amount of their energy within this bandwidth.
3. **Ultraviolet C (UV-C)** - UV of short wavelength below 280nm (we say from 280 to 200 nm) – a large amount of this energy is present in the Sunlight.
4. **Visible** – Light that can be seen 400-700 nm.

**Dose** - is irradiance integrated over time, or Irradiance ( $W/cm^2$ ) x Time (s) = Dose (Joules/cm<sup>2</sup>). Note: Watt is the power that gives rise to the production of energy at the rate of 1-joule (J) per second(s).

**Ozone** - oxidizing agent (O<sub>3</sub>) produced by the action of Ultraviolet radiant energy (below 185 nm) or electrical corona discharge of oxygen on air.

**OSHA 1910.145:** "Regulation of Accident prevention Signs and Tags" defines the following headers as:

**WARNING** – is used when there is a hazardous situation that has some probability of severe injury.

**CAUTION** - is used to indicate a hazardous situation that may result in minor or moderate injury.

**NOTICE** - is used to convey a message related directly or indirectly to the safety of personnel, or protection of property.

## WARRANTY

### CAUTION!

DYMAX CORPORATION RESERVES THE RIGHT TO INVALIDATE ANY WARRANTIES, EXPRESSED OR IMPLIED, DUE TO ANY REPAIRS PERFORMED OR ATTEMPTED ON DYMAX EQUIPMENT WITHOUT WRITTEN AUTHORIZATION FROM DYMAX. THOSE CORRECTIVE ACTIONS LISTED BELOW ARE LIMITED TO THIS AUTHORIZATION.

DYMAX offers a one-year warranty against defects in material and workmanship on all system components *with proof of purchase date*. Unauthorized repair, modification, or improper use of equipment may void warranty. The use of aftermarket replacement parts not supplied or approved by DYMAX Corporation, will void any effective warranties and may result in damage to the equipment.

For further assistance with adhesive and equipment selection, contact DYMAX Applications Engineering.



In the U.S. Call: 877.396.2988  
In North and South America Call: +1.860.482.1010  
In Europe Call: +49 (0) 611.962.7900  
In China Call: +86.755.83485759  
In Asia Call: +852.2460.7038  
In Korea Call: +82.2.784.3434

[www.dymax.com](http://www.dymax.com) ♦ [www.dymax.de](http://www.dymax.de) ♦ [www.dymax.com.cn](http://www.dymax.com.cn) ♦ [www.dymax.co.kr](http://www.dymax.co.kr)

**DYMAX Corporation** - 318 Industrial Lane - Torrington, CT 06790 - Phone: 860.482.1010 - Fax: 860.496.0608 - E-mail: [info@dymax.com](mailto:info@dymax.com) - [www.dymax.com](http://www.dymax.com)

**DYMAX Europe GmbH** - Kasteler Strasse 45 - Building G 359 - 65203 Wiesbaden, Germany - Phone: +49 (0) 611.962.7900 - Fax: +49 (0) 611.962.9440 - E-mail: [info\\_de@dymax.com](mailto:info_de@dymax.com) - [www.dymax.de](http://www.dymax.de)

**DYMAX UV Adhesives & Equipment (Shenzhen) Co., Ltd** - Unit 807, Talfook Building, No. 9 Shihua Road, Futian Free Trade Zone, Shenzhen, China 518038 - Phone: +86.755.83485759 - Fax: +86.755.83485760 - E-mail: [dymaxasia@dymax.com](mailto:dymaxasia@dymax.com) - [www.dymax.com.cn](http://www.dymax.com.cn)

**DYMAX Asia (HK)** - Room 1103, 11/F, Metro Centre, Phase I, 32 Lam Hing St., Kowloon Bay, Hong Kong - Phone: +852.2460.7038 - Fax: +852.2460.7017 - E-mail: [dymaxasia@dymax.com](mailto:dymaxasia@dymax.com) - [www.dymax.com.cn](http://www.dymax.com.cn)

**DYMAX Korea LLC** - #903, CCMM B/D, 12 Yeoido-Dong, Youngdungpo-Gu, Seoul, Korea, 150-869 - Phone: +82.2.784.3434 - Fax: +82.2.784.5775 - E-mail: [info@dymax.kr](mailto:info@dymax.kr) - [www.dymax.co.kr](http://www.dymax.co.kr)

© 2006-2011 DYMAX Corporation. All rights reserved. All trademarks in this guide, except where noted, are the property of, or used under license by DYMAX Corporation, U.S.A.

The data contained in this bulletin is of a general nature and is based on laboratory test conditions. DYMAX does not warrant the data contained in this bulletin. Any warranty applicable to the product, its application and use is strictly limited to that contained in DYMAX's standard Conditions of Sale. DYMAX does not assume responsibility for test or performance results obtained by users. It is the user's responsibility to determine the suitability for the product application and purposes and the suitability for use in the user's intended manufacturing apparatus and methods. The user should adopt such precautions and use guidelines as may be reasonably advisable or necessary for the protection of property and persons. Nothing in this bulletin shall act as a representation that the product use or application will not infringe a patent owned by someone other than DYMAX or act as a grant of license under any DYMAX Corporation Patent. DYMAX recommends that each user adequately test its proposed use and application before actual repetitive use, using the data contained in this bulletin as a general guide

PN38321 4/18/2011