

ZIP™ Shutter for Use with DYMAX UV Lamps

An Accessory for UV Curing Control & Safety - **CE Marked**

The DYMAX ZIP™ shutter is designed as an accessory to use with DYMAX UV flood lamps to control UV exposure time. Shutters also prevent operator exposure when opening shields.

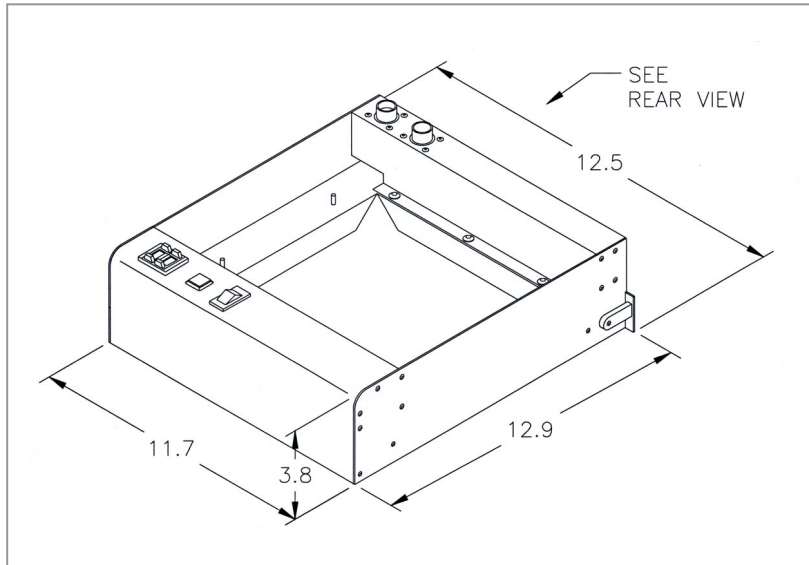

DYMAX flood lamps require a few minutes to warm up after ignition. Turning the lamp off and on negatively affects the lifetime of the bulb. With a DYMAX shutter installed, the flood lamp may stay on continuously. Objects may be loaded and unloaded from beneath the shutter when it is shut without exposing operators to ultraviolet light. In addition, precise control of exposure times can be achieved.

The shutter can be operated in two modes: Timed and Manual. In timed mode, the shutter opens by pressing a button on the front panel or by activating the remote switch (i.e. foot pedal switch), and remains open for a user-specified period of time.

In the manual mode, pressing the button on the front panel or remote switch (i.e. foot pedal) opens the shutter and releasing the button closes the shutter.

Compatible Flood Lamps	DYMAX 2000 Series and 5000 Series
Remote Control	Via foot pedal
Range	1 to 99 seconds (1 second increments)
Accuracy and Repeatability	For settings below 30 seconds (± 1 second) For settings above 30 seconds (± 2 seconds)
Part Number	37863 - (includes shutter & foot pedal switch with connector cable)

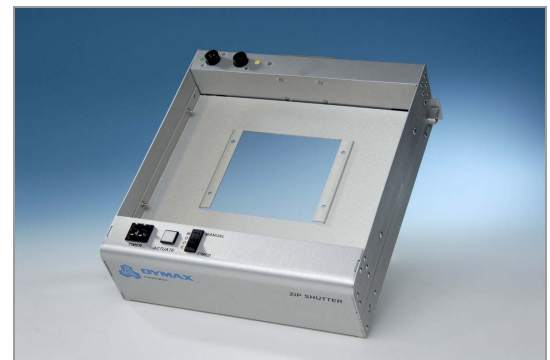

DYMAX Corporation - 318 Industrial Lane - Torrington, CT 06790 - Phone: 860.482.1010 - Fax: 860.496.0608 - E-mail: info@dymax.com - www.dymax.com

DYMAX Europe GmbH – Kasteler Strasse 45 - Building G 359 - 65203 Wiesbaden, Germany - Phone: +49 (0) 61 1.962.7900 - Fax: +49 (0) 611.962.9440 - E-mail: info_de@dymax.com - www.dymax.de

DYMAX UV Adhesives & Equipment (Shenzhen) Co., Ltd - Unit 807, Talfook Building, No. 9 Shihua Road, Futian Free Trade Zone, Shenzhen, China 518038 - Phone: +86.755.83485759 - Fax: +86.755.83485760 - E-mail: dymaxasia@dymax.com - www.dymax.com.cn

DYMAX Asia (HK) - Room 1103, 11/F., Metro Centre, Phase I, 32 Lam Hing St., Kowloon Bay, Hong Kong - Phone: +852.2460.7038 - Fax: +852.2460.7017 - E-mail: dymaxasia@dymax.com - www.dymax.com.cn

DYMAX Korea LLC - #903, CCMM B/D, 12 Yeoido-Dong, Youngdungpo-Gu, Seoul, Korea, 150-869 - Phone: 82.2.784.3434 - Fax: 82.2.784.5775 - E-mail: info@dymax.kr - www.dymax.co.kr

© 2001-2007 DYMAX Corporation. All rights reserved. All trademarks in this guide, except where noted, are the property of, or used under license by DYMAX Corporation, U.S.A.

Please note that most dispensing and curing system applications are unique. DYMAX does not warrant the fitness of the product for the intended application. Any warranty applicable to the product, its application and use is strictly limited to that contained in DYMAX's standard Conditions of Sale. DYMAX recommends that any intended application be evaluated and tested by the user to insure that desired performance criteria are satisfied. DYMAX is willing to assist users in their performance testing and evaluation by offering equipment trial rental and leasing programs to assist in such testing and evaluation. Data sheets are available for valve controllers or pressure pots upon request.

LIT068R 3/19/2007